









SHACMAN(1)

	<table border="1"> <tr><td>Part No.</td><td>QH50 G160T</td></tr> <tr><td>CH part name</td><td>取力器</td></tr> <tr><td>EN part name</td><td>Power take off</td></tr> <tr><td>RU part name</td><td>Коробка отбора мощности</td></tr> <tr><td>Size:mm</td><td>270*260*150</td></tr> <tr><td>Weight:kg</td><td>16.8</td></tr> <tr><td>Price:usd</td><td></td></tr> </table>	Part No.	QH50 G160T	CH part name	取力器	EN part name	Power take off	RU part name	Коробка отбора мощности	Size:mm	270*260*150	Weight:kg	16.8	Price:usd			<table border="1"> <tr><td>Part No.</td><td>ZQC1200</td></tr> <tr><td>CH part name</td><td>分动箱</td></tr> <tr><td>EN part name</td><td>TRANSFER GEAR BOX</td></tr> <tr><td>RU part name</td><td>передача коробки передач</td></tr> <tr><td>Size:mm</td><td></td></tr> <tr><td>Weight:kg</td><td>189</td></tr> <tr><td>Price:usd</td><td></td></tr> </table>	Part No.	ZQC1200	CH part name	分动箱	EN part name	TRANSFER GEAR BOX	RU part name	передача коробки передач	Size:mm		Weight:kg	189	Price:usd	
Part No.	QH50 G160T																														
CH part name	取力器																														
EN part name	Power take off																														
RU part name	Коробка отбора мощности																														
Size:mm	270*260*150																														
Weight:kg	16.8																														
Price:usd																															
Part No.	ZQC1200																														
CH part name	分动箱																														
EN part name	TRANSFER GEAR BOX																														
RU part name	передача коробки передач																														
Size:mm																															
Weight:kg	189																														
Price:usd																															
Remarks: SHACMAN F2000 F3000		Remarks: SHACMAN F2000 F3000 8*4																													
	<table border="1"> <tr><td>Part No.</td><td>QH70</td></tr> <tr><td>CH part name</td><td>取力器</td></tr> <tr><td>EN part name</td><td>Power take off</td></tr> <tr><td>RU part name</td><td>Коробка отбора мощности</td></tr> <tr><td>Size:mm</td><td></td></tr> <tr><td>Weight:kg</td><td>22.5</td></tr> <tr><td>Price:usd</td><td></td></tr> </table>	Part No.	QH70	CH part name	取力器	EN part name	Power take off	RU part name	Коробка отбора мощности	Size:mm		Weight:kg	22.5	Price:usd			<table border="1"> <tr><td>Part No.</td><td>QH50-169</td></tr> <tr><td>CH part name</td><td>取力器</td></tr> <tr><td>EN part name</td><td>Power take off</td></tr> <tr><td>RU part name</td><td>Коробка отбора мощности</td></tr> <tr><td>Size:mm</td><td>270*260*150</td></tr> <tr><td>Weight:kg</td><td>19.8</td></tr> <tr><td>Price:usd</td><td></td></tr> </table>	Part No.	QH50-169	CH part name	取力器	EN part name	Power take off	RU part name	Коробка отбора мощности	Size:mm	270*260*150	Weight:kg	19.8	Price:usd	
Part No.	QH70																														
CH part name	取力器																														
EN part name	Power take off																														
RU part name	Коробка отбора мощности																														
Size:mm																															
Weight:kg	22.5																														
Price:usd																															
Part No.	QH50-169																														
CH part name	取力器																														
EN part name	Power take off																														
RU part name	Коробка отбора мощности																														
Size:mm	270*260*150																														
Weight:kg	19.8																														
Price:usd																															
Remarks: SHACMAN F2000 F3000		Remarks: SHACMAN F2000 F3000																													
	<table border="1"> <tr><td>Part No.</td><td>AZ9112220254G4180</td></tr> <tr><td>CH part name</td><td>变速箱总成</td></tr> <tr><td>EN part name</td><td>Gearbox assy.</td></tr> <tr><td>RU part name</td><td>ступенчатая КПП в сборе</td></tr> <tr><td>Size:mm</td><td>1000*650*600</td></tr> <tr><td>Weight:kg</td><td>350</td></tr> <tr><td>Price:usd</td><td></td></tr> </table>	Part No.	AZ9112220254G4180	CH part name	变速箱总成	EN part name	Gearbox assy.	RU part name	ступенчатая КПП в сборе	Size:mm	1000*650*600	Weight:kg	350	Price:usd			<table border="1"> <tr><td>Part No.</td><td>AZ9112220254G2429</td></tr> <tr><td>CH part name</td><td>变速箱</td></tr> <tr><td>EN part name</td><td>Gearbox assy.</td></tr> <tr><td>RU part name</td><td>ступенчатая КПП в сборе</td></tr> <tr><td>Size:mm</td><td>1000*650*600</td></tr> <tr><td>Weight:kg</td><td>320</td></tr> <tr><td>Price:usd</td><td></td></tr> </table>	Part No.	AZ9112220254G2429	CH part name	变速箱	EN part name	Gearbox assy.	RU part name	ступенчатая КПП в сборе	Size:mm	1000*650*600	Weight:kg	320	Price:usd	
Part No.	AZ9112220254G4180																														
CH part name	变速箱总成																														
EN part name	Gearbox assy.																														
RU part name	ступенчатая КПП в сборе																														
Size:mm	1000*650*600																														
Weight:kg	350																														
Price:usd																															
Part No.	AZ9112220254G2429																														
CH part name	变速箱																														
EN part name	Gearbox assy.																														
RU part name	ступенчатая КПП в сборе																														
Size:mm	1000*650*600																														
Weight:kg	320																														
Price:usd																															
Remarks: SHACMAN 12JS160TA,12JS180TA,12JS200TA		Remarks: SHACMAN RT11509C																													
	<table border="1"> <tr><td>Part No.</td><td>AZ9112220254</td></tr> <tr><td>CH part name</td><td>变速箱总成G2800</td></tr> <tr><td>EN part name</td><td>Gearbox assy.</td></tr> <tr><td>RU part name</td><td>ступенчатая КПП в сборе</td></tr> <tr><td>Size:mm</td><td>1000*650*600</td></tr> <tr><td>Weight:kg</td><td>350</td></tr> <tr><td>Price:usd</td><td></td></tr> </table>	Part No.	AZ9112220254	CH part name	变速箱总成G2800	EN part name	Gearbox assy.	RU part name	ступенчатая КПП в сборе	Size:mm	1000*650*600	Weight:kg	350	Price:usd			<table border="1"> <tr><td>Part No.</td><td>SZ922000010</td></tr> <tr><td>CH part name</td><td>变速箱G4219</td></tr> <tr><td>EN part name</td><td>Gearbox assy.</td></tr> <tr><td>RU part name</td><td>9-ступенчатая КПП в сборе</td></tr> <tr><td>Size:mm</td><td>1000*650*600</td></tr> <tr><td>Weight:kg</td><td>300</td></tr> <tr><td>Price:usd</td><td></td></tr> </table>	Part No.	SZ922000010	CH part name	变速箱G4219	EN part name	Gearbox assy.	RU part name	9-ступенчатая КПП в сборе	Size:mm	1000*650*600	Weight:kg	300	Price:usd	
Part No.	AZ9112220254																														
CH part name	变速箱总成G2800																														
EN part name	Gearbox assy.																														
RU part name	ступенчатая КПП в сборе																														
Size:mm	1000*650*600																														
Weight:kg	350																														
Price:usd																															
Part No.	SZ922000010																														
CH part name	变速箱G4219																														
EN part name	Gearbox assy.																														
RU part name	9-ступенчатая КПП в сборе																														
Size:mm	1000*650*600																														
Weight:kg	300																														
Price:usd																															
Remarks:SHACMAN 12JS160T,12JS180T,12JS200T,12JS220T SZ922000119 G5570		Remarks:SHACMAN 9JS119																													

SHACMAN(1)

transmission		NO.56	transmission		NO.A56
KD0954			KD0955		
	Part No.	JS180-1601021-1		Part No.	J75-11601033
	CH part name	离合器拨叉		CH part name	分离轴承润滑管
	EN part name	Release fork		EN part name	Hose
	RU part name	Вилка выключения сцепления		RU part name	Шланг
	Size:mm	430*150*50		Size:mm	
	Weight:kg	4		Weight:kg	0.19
	NO.	NO.A56-21		NO.	NO.A56-23
Remarks:SHACMAN F3000 F2000			Remarks:SHACMAN F3000 F2000		
KD0956			KD0957		
	Part No.	12817		Part No.	51016
	CH part name	离合器拨叉		CH part name	分离#由承润滑管
	EN part name	Release fork		EN part name	Hose
	RU part name	Вилка выключения сцепления		RU part name	Шланг
	Size:mm	130*100*30		Size:mm	230*15*15
	Weight:kg	0.8		Weight:kg	0.15
	NO.	NO.56-14		NO.	NO.56-18
Remarks:SHACMAN F3000 F2000 RT-11509C			Remarks:SHACMAN F3000 F2000 RT-11509C		







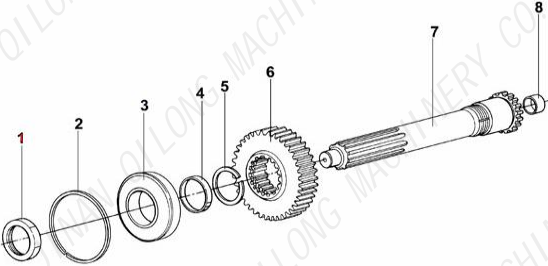

SHACMAN(1)

PRO PELLER SHAFT		NO.60															
		KD1103															
			<table border="1"> <tr><td>Part No.</td><td>26013314080</td></tr> <tr><td>CH part name</td><td>万向节Φ52</td></tr> <tr><td>EN part name</td><td>Universal joint assy.</td></tr> <tr><td>RU part name</td><td>Креставина в сборе</td></tr> <tr><td>Size:mm</td><td>130*130*52</td></tr> <tr><td>Weight:kg</td><td>3</td></tr> <tr><td>NO.</td><td>NO.60-3</td></tr> </table>	Part No.	26013314080	CH part name	万向节Φ52	EN part name	Universal joint assy.	RU part name	Креставина в сборе	Size:mm	130*130*52	Weight:kg	3	NO.	NO.60-3
Part No.	26013314080																
CH part name	万向节Φ52																
EN part name	Universal joint assy.																
RU part name	Креставина в сборе																
Size:mm	130*130*52																
Weight:kg	3																
NO.	NO.60-3																
		Remarks: SHACMAN F3000 F2000															
		KD1104															
			<table border="1"> <tr><td>Part No.</td><td>DZ91189313901</td></tr> <tr><td>CH part name</td><td>万向节Φ62</td></tr> <tr><td>EN part name</td><td>Universal joint assy.</td></tr> <tr><td>RU part name</td><td>Креставина в сборе</td></tr> <tr><td>Size:mm</td><td>145*145*62</td></tr> <tr><td>Weight:kg</td><td>4.5</td></tr> <tr><td>NO.</td><td>NO.60-3</td></tr> </table>	Part No.	DZ91189313901	CH part name	万向节Φ62	EN part name	Universal joint assy.	RU part name	Креставина в сборе	Size:mm	145*145*62	Weight:kg	4.5	NO.	NO.60-3
Part No.	DZ91189313901																
CH part name	万向节Φ62																
EN part name	Universal joint assy.																
RU part name	Креставина в сборе																
Size:mm	145*145*62																
Weight:kg	4.5																
NO.	NO.60-3																
		Remarks: SHACMAN F3000 F2000 X3000 M3000															
KD1105																	
	<table border="1"> <tr><td>Part No.</td><td>19036311080</td></tr> <tr><td>CH part name</td><td>万向节Φ57</td></tr> <tr><td>EN part name</td><td>Universal joint assy.</td></tr> <tr><td>RU part name</td><td>Креставина в сборе</td></tr> <tr><td>Size:mm</td><td>140*140*57</td></tr> <tr><td>Weight:kg</td><td>4</td></tr> <tr><td>NO.</td><td>NO.60-3</td></tr> </table>	Part No.	19036311080	CH part name	万向节Φ57	EN part name	Universal joint assy.	RU part name	Креставина в сборе	Size:mm	140*140*57	Weight:kg	4	NO.	NO.60-3		
Part No.	19036311080																
CH part name	万向节Φ57																
EN part name	Universal joint assy.																
RU part name	Креставина в сборе																
Size:mm	140*140*57																
Weight:kg	4																
NO.	NO.60-3																
		Remarks: SHACMAN F3000 F2000 X3000 M3000															
KD1106																	
	<table border="1"> <tr><td>Part No.</td><td>26013314030-70LX</td></tr> <tr><td>CH part name</td><td>传动轴吊架</td></tr> <tr><td>EN part name</td><td>Transmission hanger assy.</td></tr> <tr><td>RU part name</td><td>Промежуточная опора в сборе</td></tr> <tr><td>Size:mm</td><td></td></tr> <tr><td>Weight:kg</td><td>4.95</td></tr> <tr><td>NO.</td><td>NO.60-9</td></tr> </table>	Part No.	26013314030-70LX	CH part name	传动轴吊架	EN part name	Transmission hanger assy.	RU part name	Промежуточная опора в сборе	Size:mm		Weight:kg	4.95	NO.	NO.60-9		
Part No.	26013314030-70LX																
CH part name	传动轴吊架																
EN part name	Transmission hanger assy.																
RU part name	Промежуточная опора в сборе																
Size:mm																	
Weight:kg	4.95																
NO.	NO.60-9																
		Remarks: SHACMAN F3000 F2000 X3000 M3000															
KD1107																	
	<table border="1"> <tr><td>Part No.</td><td>26013314030-75</td></tr> <tr><td>CH part name</td><td>传动轴吊架</td></tr> <tr><td>EN part name</td><td>Transmission hanger assy.</td></tr> <tr><td>RU part name</td><td>Промежуточная опора в сборе</td></tr> <tr><td>Size:mm</td><td></td></tr> <tr><td>Weight:kg</td><td>5</td></tr> <tr><td>NO.</td><td>NO.60-9</td></tr> </table>	Part No.	26013314030-75	CH part name	传动轴吊架	EN part name	Transmission hanger assy.	RU part name	Промежуточная опора в сборе	Size:mm		Weight:kg	5	NO.	NO.60-9		
Part No.	26013314030-75																
CH part name	传动轴吊架																
EN part name	Transmission hanger assy.																
RU part name	Промежуточная опора в сборе																
Size:mm																	
Weight:kg	5																
NO.	NO.60-9																
		Remarks: SHACMAN F3000 F2000 X3000 M3000															
KD1108																	
	<table border="1"> <tr><td>Part No.</td><td>26013314030-80LX</td></tr> <tr><td>CH part name</td><td>传动轴吊架</td></tr> <tr><td>EN part name</td><td>Transmission hanger assy.</td></tr> <tr><td>RU part name</td><td>Промежуточная опора в сборе</td></tr> <tr><td>Size:mm</td><td></td></tr> <tr><td>Weight:kg</td><td>5.15</td></tr> <tr><td>NO.</td><td>NO.60-9</td></tr> </table>	Part No.	26013314030-80LX	CH part name	传动轴吊架	EN part name	Transmission hanger assy.	RU part name	Промежуточная опора в сборе	Size:mm		Weight:kg	5.15	NO.	NO.60-9		
Part No.	26013314030-80LX																
CH part name	传动轴吊架																
EN part name	Transmission hanger assy.																
RU part name	Промежуточная опора в сборе																
Size:mm																	
Weight:kg	5.15																
NO.	NO.60-9																
		Remarks: SHACMAN F3000 F2000 X3000 M3000															

SHACMAN(1)

	<p>KD0958</p> <table border="1"> <tr><td>Part No.</td><td>199112230033</td></tr> <tr><td>CH part name</td><td>拨叉轴焊接总成</td></tr> <tr><td>EN part name</td><td>The shaft for release bearing</td></tr> <tr><td>RU part name</td><td>Вилка выключения сцепления</td></tr> <tr><td>Size:mm</td><td>650*90*40</td></tr> <tr><td>Weight:kg</td><td>2.25</td></tr> <tr><td>NO.</td><td>NO.56-29</td></tr> </table>	Part No.	199112230033	CH part name	拨叉轴焊接总成	EN part name	The shaft for release bearing	RU part name	Вилка выключения сцепления	Size:mm	650*90*40	Weight:kg	2.25	NO.	NO.56-29		<p>KD0959</p> <table border="1"> <tr><td>Part No.</td><td>JS180-1601023-3</td></tr> <tr><td>CH part name</td><td>离合器拨叉轴</td></tr> <tr><td>EN part name</td><td>The shaft for release bearing</td></tr> <tr><td>RU part name</td><td>Вилка выключения сцепления</td></tr> <tr><td>Size:mm</td><td></td></tr> <tr><td>Weight:kg</td><td>0.16</td></tr> <tr><td>NO.</td><td>NO.A56-22</td></tr> </table>	Part No.	JS180-1601023-3	CH part name	离合器拨叉轴	EN part name	The shaft for release bearing	RU part name	Вилка выключения сцепления	Size:mm		Weight:kg	0.16	NO.	NO.A56-22
Part No.	199112230033																														
CH part name	拨叉轴焊接总成																														
EN part name	The shaft for release bearing																														
RU part name	Вилка выключения сцепления																														
Size:mm	650*90*40																														
Weight:kg	2.25																														
NO.	NO.56-29																														
Part No.	JS180-1601023-3																														
CH part name	离合器拨叉轴																														
EN part name	The shaft for release bearing																														
RU part name	Вилка выключения сцепления																														
Size:mm																															
Weight:kg	0.16																														
NO.	NO.A56-22																														
Remarks:SHACMAN F3000 F2000 RT-11509C		Remarks:SHACMAN F3000 F2000																													
	<p>KD0960</p> <table border="1"> <tr><td>Part No.</td><td>11203</td></tr> <tr><td>CH part name</td><td>分离轴承座</td></tr> <tr><td>EN part name</td><td>Release bearing holder</td></tr> <tr><td>RU part name</td><td>Седло выжимного подшипника</td></tr> <tr><td>Size:mm</td><td>102*132*87</td></tr> <tr><td>Weight:kg</td><td>1.26</td></tr> <tr><td>NO.</td><td>NO.56-20</td></tr> </table>	Part No.	11203	CH part name	分离轴承座	EN part name	Release bearing holder	RU part name	Седло выжимного подшипника	Size:mm	102*132*87	Weight:kg	1.26	NO.	NO.56-20		<p>KD0961</p> <table border="1"> <tr><td>Part No.</td><td>996914</td></tr> <tr><td>CH part name</td><td>分离轴承</td></tr> <tr><td>EN part name</td><td>Release bearing</td></tr> <tr><td>RU part name</td><td>Выжимной подшипник</td></tr> <tr><td>Size:mm</td><td>109*70*29</td></tr> <tr><td>Weight:kg</td><td>0.73</td></tr> <tr><td>NO.</td><td>NO.56-16</td></tr> </table>	Part No.	996914	CH part name	分离轴承	EN part name	Release bearing	RU part name	Выжимной подшипник	Size:mm	109*70*29	Weight:kg	0.73	NO.	NO.56-16
Part No.	11203																														
CH part name	分离轴承座																														
EN part name	Release bearing holder																														
RU part name	Седло выжимного подшипника																														
Size:mm	102*132*87																														
Weight:kg	1.26																														
NO.	NO.56-20																														
Part No.	996914																														
CH part name	分离轴承																														
EN part name	Release bearing																														
RU part name	Выжимной подшипник																														
Size:mm	109*70*29																														
Weight:kg	0.73																														
NO.	NO.56-16																														
Remarks:SHACMAN F3000 F2000 RT-11509C		Remarks:SHACMAN F3000 F2000 RT-11509C																													
	<p>KD0962</p> <table border="1"> <tr><td>Part No.</td><td>4425</td></tr> <tr><td>CH part name</td><td>分离轴承拉簧</td></tr> <tr><td>EN part name</td><td>Spring</td></tr> <tr><td>RU part name</td><td>весной</td></tr> <tr><td>Size:mm</td><td></td></tr> <tr><td>Weight:kg</td><td>0.01</td></tr> <tr><td>Price:usd</td><td>NO.56-17</td></tr> </table>	Part No.	4425	CH part name	分离轴承拉簧	EN part name	Spring	RU part name	весной	Size:mm		Weight:kg	0.01	Price:usd	NO.56-17		<p>KD0963</p> <table border="1"> <tr><td>Part No.</td><td>12880</td></tr> <tr><td>CH part name</td><td>45°弯管接头</td></tr> <tr><td>EN part name</td><td>45°elbow joint</td></tr> <tr><td>RU part name</td><td>Elbow совместных 45 градусов</td></tr> <tr><td>Size:mm</td><td></td></tr> <tr><td>Weight:kg</td><td>0.01</td></tr> <tr><td>Price:usd</td><td>NO.56-19</td></tr> </table>	Part No.	12880	CH part name	45°弯管接头	EN part name	45°elbow joint	RU part name	Elbow совместных 45 градусов	Size:mm		Weight:kg	0.01	Price:usd	NO.56-19
Part No.	4425																														
CH part name	分离轴承拉簧																														
EN part name	Spring																														
RU part name	весной																														
Size:mm																															
Weight:kg	0.01																														
Price:usd	NO.56-17																														
Part No.	12880																														
CH part name	45°弯管接头																														
EN part name	45°elbow joint																														
RU part name	Elbow совместных 45 градусов																														
Size:mm																															
Weight:kg	0.01																														
Price:usd	NO.56-19																														
Remarks:SHACMAN F3000 F2000 RT-11509C		Remarks:SHACMAN F3000 F2000 RT-11509C																													
	<p>KD0964</p> <table border="1"> <tr><td>Part No.</td><td>12JS160T-1701116</td></tr> <tr><td>CH part name</td><td>一轴齿轮</td></tr> <tr><td>EN part name</td><td>No 1 axle gear</td></tr> <tr><td>RU part name</td><td>Шестерня первичного вала</td></tr> <tr><td>Size:mm</td><td></td></tr> <tr><td>Weight:kg</td><td>4.5</td></tr> <tr><td>Price:usd</td><td>NO.57-6</td></tr> </table>	Part No.	12JS160T-1701116	CH part name	一轴齿轮	EN part name	No 1 axle gear	RU part name	Шестерня первичного вала	Size:mm		Weight:kg	4.5	Price:usd	NO.57-6		<p>KD0965</p> <table border="1"> <tr><td>Part No.</td><td>JS180A-1701030</td></tr> <tr><td>CH part name</td><td>一轴</td></tr> <tr><td>EN part name</td><td>No.1 axle</td></tr> <tr><td>RU part name</td><td>Первичный вал</td></tr> <tr><td>Size:mm</td><td>375*80</td></tr> <tr><td>Weight:kg</td><td>4.42</td></tr> <tr><td>Price:usd</td><td>NO.57-7</td></tr> </table>	Part No.	JS180A-1701030	CH part name	一轴	EN part name	No.1 axle	RU part name	Первичный вал	Size:mm	375*80	Weight:kg	4.42	Price:usd	NO.57-7
Part No.	12JS160T-1701116																														
CH part name	一轴齿轮																														
EN part name	No 1 axle gear																														
RU part name	Шестерня первичного вала																														
Size:mm																															
Weight:kg	4.5																														
Price:usd	NO.57-6																														
Part No.	JS180A-1701030																														
CH part name	一轴																														
EN part name	No.1 axle																														
RU part name	Первичный вал																														
Size:mm	375*80																														
Weight:kg	4.42																														
Price:usd	NO.57-7																														
Remarks:SHACMAN 12JS200T-1701116		Remarks:SHACMAN F3000 F2000 JS180-1701030-S																													

SHACMAN(1)

A shaft		NO.57		KD0966			
						Part No.	19694-20
						CH part name	一轴
						EN part name	No.1 axle
						RU part name	Первичный вал
						Size:mm	325*80
						Weight:kg	3.69
						Price:usd	NO.57-7
Remarks:SHACMAN F3000 F2000 19694 (加大) RT-11509C							
KD0967				KD0968			
		Part No.	17568			Part No.	16566
		CH part name	一轴齿轮			CH part name	二轴导套
		EN part name	No 1 axle gear			EN part name	2nd shaft bush
		RU part name	Шестерня первичного вала			RU part name	Направляющая втулка вторичного вала
		Size:mm				Size:mm	82*52*40
		Weight:kg	4.5			Weight:kg	0.55
		Price:usd	NO.57-6			Price:usd	NO.57-8
Remarks:SHACMAN F3000 F2000 RT-11509C				Remarks:SHACMAN F3000 F2000			
KD0969				KD0970			
		Part No.	C01021			Part No.	150212K
		CH part name	止动环			CH part name	一轴轴承
		EN part name	Stop ring			EN part name	Bearing
		RU part name	прекрати кольцо			RU part name	принимая
		Size:mm				Size:mm	110*110*22
		Weight:kg	0.04			Weight:kg	0.783
		Price:usd	NO.57-2			Price:usd	NO.57-3
Remarks:SHACMAN F3000 F2000 RT-11509C				Remarks:SHACMAN F3000 F2000			
KD0971				KD0972			
		Part No.	8858			Part No.	JS180A-1701036
		CH part name	一轴螺母			CH part name	一轴螺母
		EN part name	No. 1 axle nut			EN part name	No. 1 axle nut
		RU part name	Гайка первичного вала			RU part name	Гайка первичного вала
		Size:mm	85*53*12			Size:mm	100*100*10
		Weight:kg	0.21			Weight:kg	0.6
		Price:usd	NO.57-1			Price:usd	NO.57-1
Remarks:SHACMAN F3000 F2000 RT-11509C				Remarks:SHACMAN F3000 F2000			

SHACMAN(1)

	<table border="1"> <tr><td>Part No.</td><td>12JS160T-1701105</td></tr> <tr><td>CH part name</td><td>二轴</td></tr> <tr><td>EN part name</td><td>2nd shaft</td></tr> <tr><td>RU part name</td><td>Вторичный вал</td></tr> <tr><td>Size:mm</td><td></td></tr> <tr><td>Weight:kg</td><td>5.2</td></tr> <tr><td>Price:usd</td><td>NO.58-8a</td></tr> </table>	Part No.	12JS160T-1701105	CH part name	二轴	EN part name	2nd shaft	RU part name	Вторичный вал	Size:mm		Weight:kg	5.2	Price:usd	NO.58-8a		<table border="1"> <tr><td>Part No.</td><td>18729</td></tr> <tr><td>CH part name</td><td>二轴</td></tr> <tr><td>EN part name</td><td>2nd shaft</td></tr> <tr><td>RU part name</td><td>Вторичный вал</td></tr> <tr><td>Size:mm</td><td>455*56</td></tr> <tr><td>Weight:kg</td><td>5.2</td></tr> <tr><td>Price:usd</td><td>NO.58-8a</td></tr> </table>	Part No.	18729	CH part name	二轴	EN part name	2nd shaft	RU part name	Вторичный вал	Size:mm	455*56	Weight:kg	5.2	Price:usd	NO.58-8a
Part No.	12JS160T-1701105																														
CH part name	二轴																														
EN part name	2nd shaft																														
RU part name	Вторичный вал																														
Size:mm																															
Weight:kg	5.2																														
Price:usd	NO.58-8a																														
Part No.	18729																														
CH part name	二轴																														
EN part name	2nd shaft																														
RU part name	Вторичный вал																														
Size:mm	455*56																														
Weight:kg	5.2																														
Price:usd	NO.58-8a																														
Remarks:SHACMAN F3000 F2000 12JS200T-1701105 J80A-1701105		Remarks:SHACMAN F3000 F2000 RT-11509C																													
	<table border="1"> <tr><td>Part No.</td><td>016118</td></tr> <tr><td>CH part name</td><td>二轴滑套</td></tr> <tr><td>EN part name</td><td>2nd shaft sliding sleeve</td></tr> <tr><td>RU part name</td><td>Скользящая муфта вторичного вала</td></tr> <tr><td>Size:mm</td><td>80*40*57</td></tr> <tr><td>Weight:kg</td><td>0.56</td></tr> <tr><td>Price:usd</td><td>NO.58-2</td></tr> </table>	Part No.	016118	CH part name	二轴滑套	EN part name	2nd shaft sliding sleeve	RU part name	Скользящая муфта вторичного вала	Size:mm	80*40*57	Weight:kg	0.56	Price:usd	NO.58-2		<table border="1"> <tr><td>Part No.</td><td>14749</td></tr> <tr><td>CH part name</td><td>二轴齿轮花键垫片</td></tr> <tr><td>EN part name</td><td>Splined washer</td></tr> <tr><td>RU part name</td><td>splined шайбы</td></tr> <tr><td>Size:mm</td><td>58*81*5</td></tr> <tr><td>Weight:kg</td><td>0.1</td></tr> <tr><td>Price:usd</td><td>NO.58-3</td></tr> </table>	Part No.	14749	CH part name	二轴齿轮花键垫片	EN part name	Splined washer	RU part name	splined шайбы	Size:mm	58*81*5	Weight:kg	0.1	Price:usd	NO.58-3
Part No.	016118																														
CH part name	二轴滑套																														
EN part name	2nd shaft sliding sleeve																														
RU part name	Скользящая муфта вторичного вала																														
Size:mm	80*40*57																														
Weight:kg	0.56																														
Price:usd	NO.58-2																														
Part No.	14749																														
CH part name	二轴齿轮花键垫片																														
EN part name	Splined washer																														
RU part name	splined шайбы																														
Size:mm	58*81*5																														
Weight:kg	0.1																														
Price:usd	NO.58-3																														
Remarks:SHACMAN F3000 F2000 RT-11509C		Remarks:SHACMAN F3000 F2000 RT-11509C 12JS200T-1701122 12JS160T-1701122																													
	<table border="1"> <tr><td>Part No.</td><td>16748</td></tr> <tr><td>CH part name</td><td>二轴三档齿轮</td></tr> <tr><td>EN part name</td><td>Gear , 3rd speed</td></tr> <tr><td>RU part name</td><td>передача, 3-й скорость</td></tr> <tr><td>Size:mm</td><td></td></tr> <tr><td>Weight:kg</td><td>2.95</td></tr> <tr><td>Price:usd</td><td>NO.58-4</td></tr> </table>	Part No.	16748	CH part name	二轴三档齿轮	EN part name	Gear , 3rd speed	RU part name	передача, 3-й скорость	Size:mm		Weight:kg	2.95	Price:usd	NO.58-4		<table border="1"> <tr><td>Part No.</td><td>16750</td></tr> <tr><td>CH part name</td><td>二轴二档齿轮</td></tr> <tr><td>EN part name</td><td>Gear , 2nd speed</td></tr> <tr><td>RU part name</td><td>передача, 2 - й скорости</td></tr> <tr><td>Size:mm</td><td></td></tr> <tr><td>Weight:kg</td><td>2.95</td></tr> <tr><td>Price:usd</td><td>NO.58-6</td></tr> </table>	Part No.	16750	CH part name	二轴二档齿轮	EN part name	Gear , 2nd speed	RU part name	передача, 2 - й скорости	Size:mm		Weight:kg	2.95	Price:usd	NO.58-6
Part No.	16748																														
CH part name	二轴三档齿轮																														
EN part name	Gear , 3rd speed																														
RU part name	передача, 3-й скорость																														
Size:mm																															
Weight:kg	2.95																														
Price:usd	NO.58-4																														
Part No.	16750																														
CH part name	二轴二档齿轮																														
EN part name	Gear , 2nd speed																														
RU part name	передача, 2 - й скорости																														
Size:mm																															
Weight:kg	2.95																														
Price:usd	NO.58-6																														
Remarks:SHACMAN F3000 F2000 RT-11509C		Remarks:SHACMAN F3000 F2000 RT-11509C																													
	<table border="1"> <tr><td>Part No.</td><td>16754</td></tr> <tr><td>CH part name</td><td>二轴低档齿轮</td></tr> <tr><td>EN part name</td><td>Gear , low speed</td></tr> <tr><td>RU part name</td><td>низкая скорость света</td></tr> <tr><td>Size:mm</td><td>220*80*37</td></tr> <tr><td>Weight:kg</td><td>4.55</td></tr> <tr><td>Price:usd</td><td>NO.58-8</td></tr> </table>	Part No.	16754	CH part name	二轴低档齿轮	EN part name	Gear , low speed	RU part name	низкая скорость света	Size:mm	220*80*37	Weight:kg	4.55	Price:usd	NO.58-8		<table border="1"> <tr><td>Part No.</td><td>12JS200T-1701111</td></tr> <tr><td>CH part name</td><td>二轴一档齿轮</td></tr> <tr><td>EN part name</td><td>Geal',1st speed</td></tr> <tr><td>RU part name</td><td>geal ", 1 - й скорости</td></tr> <tr><td>Size:mm</td><td></td></tr> <tr><td>Weight:kg</td><td>4.1</td></tr> <tr><td>Price:usd</td><td>NO.58-7</td></tr> </table>	Part No.	12JS200T-1701111	CH part name	二轴一档齿轮	EN part name	Geal',1st speed	RU part name	geal ", 1 - й скорости	Size:mm		Weight:kg	4.1	Price:usd	NO.58-7
Part No.	16754																														
CH part name	二轴低档齿轮																														
EN part name	Gear , low speed																														
RU part name	низкая скорость света																														
Size:mm	220*80*37																														
Weight:kg	4.55																														
Price:usd	NO.58-8																														
Part No.	12JS200T-1701111																														
CH part name	二轴一档齿轮																														
EN part name	Geal',1st speed																														
RU part name	geal ", 1 - й скорости																														
Size:mm																															
Weight:kg	4.1																														
Price:usd	NO.58-7																														
Remarks:SHACMAN F3000 F2000 RT-11509C JS150T-1701110		Remarks:SHACMAN F3000 F2000 RT-11509C 19246 12JS160T-1701111																													

SHACMAN(1)

	<table border="1"> <tr><td>Part No.</td><td>12JS160T-1701115</td></tr> <tr><td>CH part name</td><td>二轴五档齿轮</td></tr> <tr><td>EN part name</td><td>Gear, 5th speed</td></tr> <tr><td>RU part name</td><td>Два вал пять передача</td></tr> <tr><td>Size:mm</td><td></td></tr> <tr><td>Weight:kg</td><td>2.4</td></tr> <tr><td>Price:usd</td><td>NO.58-14</td></tr> </table>	Part No.	12JS160T-1701115	CH part name	二轴五档齿轮	EN part name	Gear, 5th speed	RU part name	Два вал пять передача	Size:mm		Weight:kg	2.4	Price:usd	NO.58-14		<table border="1"> <tr><td>Part No.</td><td>12JS200T-1701114</td></tr> <tr><td>CH part name</td><td>二轴四档齿轮</td></tr> <tr><td>EN part name</td><td>Gear, 4th speed</td></tr> <tr><td>RU part name</td><td>Два вал четыре передача</td></tr> <tr><td>Size:mm</td><td></td></tr> <tr><td>Weight:kg</td><td>2.5</td></tr> <tr><td>Price:usd</td><td>NO.58-13</td></tr> </table>	Part No.	12JS200T-1701114	CH part name	二轴四档齿轮	EN part name	Gear, 4th speed	RU part name	Два вал четыре передача	Size:mm		Weight:kg	2.5	Price:usd	NO.58-13
Part No.	12JS160T-1701115																														
CH part name	二轴五档齿轮																														
EN part name	Gear, 5th speed																														
RU part name	Два вал пять передача																														
Size:mm																															
Weight:kg	2.4																														
Price:usd	NO.58-14																														
Part No.	12JS200T-1701114																														
CH part name	二轴四档齿轮																														
EN part name	Gear, 4th speed																														
RU part name	Два вал четыре передача																														
Size:mm																															
Weight:kg	2.5																														
Price:usd	NO.58-13																														
Remarks:SHACMAN F3000 F2000 12JS200T-1701115		Remarks:SHACMAN F3000 F2000																													
	<table border="1"> <tr><td>Part No.</td><td>12JS200T-1701113</td></tr> <tr><td>CH part name</td><td>二轴三档齿轮</td></tr> <tr><td>EN part name</td><td>Gear, 3th speed</td></tr> <tr><td>RU part name</td><td>Два вал три передача</td></tr> <tr><td>Size:mm</td><td></td></tr> <tr><td>Weight:kg</td><td>3.1</td></tr> <tr><td>Price:usd</td><td>NO.58-12</td></tr> </table>	Part No.	12JS200T-1701113	CH part name	二轴三档齿轮	EN part name	Gear, 3th speed	RU part name	Два вал три передача	Size:mm		Weight:kg	3.1	Price:usd	NO.58-12		<table border="1"> <tr><td>Part No.</td><td>12JS200T-1701112</td></tr> <tr><td>CH part name</td><td>二轴二档齿轮</td></tr> <tr><td>EN part name</td><td>Gear, 2th speed</td></tr> <tr><td>RU part name</td><td>Два вал второй передача</td></tr> <tr><td>Size:mm</td><td></td></tr> <tr><td>Weight:kg</td><td>3.35</td></tr> <tr><td>Price:usd</td><td>NO.58-11</td></tr> </table>	Part No.	12JS200T-1701112	CH part name	二轴二档齿轮	EN part name	Gear, 2th speed	RU part name	Два вал второй передача	Size:mm		Weight:kg	3.35	Price:usd	NO.58-11
Part No.	12JS200T-1701113																														
CH part name	二轴三档齿轮																														
EN part name	Gear, 3th speed																														
RU part name	Два вал три передача																														
Size:mm																															
Weight:kg	3.1																														
Price:usd	NO.58-12																														
Part No.	12JS200T-1701112																														
CH part name	二轴二档齿轮																														
EN part name	Gear, 2th speed																														
RU part name	Два вал второй передача																														
Size:mm																															
Weight:kg	3.35																														
Price:usd	NO.58-11																														
Remarks: SHACMAN F3000 F2000		Remarks: SHACMAN F3000 F2000																													
	<table border="1"> <tr><td>Part No.</td><td>12JS160T-1701080</td></tr> <tr><td>CH part name</td><td>倒挡中间轴总成</td></tr> <tr><td>EN part name</td><td>Reverse shaft assembly.</td></tr> <tr><td>RU part name</td><td>Промежуточный заднего хода в сборе</td></tr> <tr><td>Size:mm</td><td></td></tr> <tr><td>Weight:kg</td><td></td></tr> <tr><td>Price:usd</td><td>NO.58-1a-5a</td></tr> </table>	Part No.	12JS160T-1701080	CH part name	倒挡中间轴总成	EN part name	Reverse shaft assembly.	RU part name	Промежуточный заднего хода в сборе	Size:mm		Weight:kg		Price:usd	NO.58-1a-5a		<table border="1"> <tr><td>Part No.</td><td>12JS160T-1701116</td></tr> <tr><td>CH part name</td><td>一轴齿轮</td></tr> <tr><td>EN part name</td><td>A shaft gear</td></tr> <tr><td>RU part name</td><td>Один вал передач</td></tr> <tr><td>Size:mm</td><td></td></tr> <tr><td>Weight:kg</td><td></td></tr> <tr><td>Price:usd</td><td>NO.58-15</td></tr> </table>	Part No.	12JS160T-1701116	CH part name	一轴齿轮	EN part name	A shaft gear	RU part name	Один вал передач	Size:mm		Weight:kg		Price:usd	NO.58-15
Part No.	12JS160T-1701080																														
CH part name	倒挡中间轴总成																														
EN part name	Reverse shaft assembly.																														
RU part name	Промежуточный заднего хода в сборе																														
Size:mm																															
Weight:kg																															
Price:usd	NO.58-1a-5a																														
Part No.	12JS160T-1701116																														
CH part name	一轴齿轮																														
EN part name	A shaft gear																														
RU part name	Один вал передач																														
Size:mm																															
Weight:kg																															
Price:usd	NO.58-15																														
Remarks:SHACMAN F3000 F2000		Remarks:SHACMAN F3000 F2000																													
	<table border="1"> <tr><td>Part No.</td><td>12JS160T-1701084</td></tr> <tr><td>CH part name</td><td>杯形倒挡垫圈</td></tr> <tr><td>EN part name</td><td>Reverse gear gasket</td></tr> <tr><td>RU part name</td><td>Cup reserve washer/шайба</td></tr> <tr><td>Size:mm</td><td>78*56*14</td></tr> <tr><td>Weight:kg</td><td>0.12</td></tr> <tr><td>NO.</td><td>NO.58-1a</td></tr> </table>	Part No.	12JS160T-1701084	CH part name	杯形倒挡垫圈	EN part name	Reverse gear gasket	RU part name	Cup reserve washer/шайба	Size:mm	78*56*14	Weight:kg	0.12	NO.	NO.58-1a		<table border="1"> <tr><td>Part No.</td><td>DS100-1701085</td></tr> <tr><td>CH part name</td><td>滚针轴承</td></tr> <tr><td>EN part name</td><td>Needle bearing</td></tr> <tr><td>RU part name</td><td>игла с</td></tr> <tr><td>Size:mm</td><td></td></tr> <tr><td>Weight:kg</td><td>0.52</td></tr> <tr><td>NO.</td><td>NO.58-3a</td></tr> </table>	Part No.	DS100-1701085	CH part name	滚针轴承	EN part name	Needle bearing	RU part name	игла с	Size:mm		Weight:kg	0.52	NO.	NO.58-3a
Part No.	12JS160T-1701084																														
CH part name	杯形倒挡垫圈																														
EN part name	Reverse gear gasket																														
RU part name	Cup reserve washer/шайба																														
Size:mm	78*56*14																														
Weight:kg	0.12																														
NO.	NO.58-1a																														
Part No.	DS100-1701085																														
CH part name	滚针轴承																														
EN part name	Needle bearing																														
RU part name	игла с																														
Size:mm																															
Weight:kg	0.52																														
NO.	NO.58-3a																														
Remarks:SHACMAN F3000 F2000 RT-11509C 16403		Remarks: SHACMAN F3000 F2000 RT-11509C 14287																													

SHACMAN(1)

2NDSHAFT, SLEEVEANDGEAR		NO.58		KD0989																															
						Part No.	JS220-1701082																												
						CH part name	倒挡中间齿轮																												
						EN part name	Shaft																												
						RU part name	вал																												
						Size:mm																													
						Weight:kg	0.15																												
						NO.	NO.58-4a																												
Remarks: SHACMAN RT-11509C 16405				KD0990																															
						Part No.	12JS160T-1701108																												
						CH part name	二轴滑套																												
						EN part name	2nd shaft sliding sleeve																												
						RU part name	Скользящая муфта вторичного вала																												
						Size:mm																													
						Weight:kg	0.5																												
						NO.	NO.58-8																												
Remarks:SHACMAN F3000 F2000 12JS200T-1701108				KD0991																															
		<table border="1"> <tr> <td>Part No.</td> <td>12JS160T-1701125</td> </tr> <tr> <td>CH part name</td> <td>二轴档齿轮垫片</td> </tr> <tr> <td>EN part name</td> <td>Shim</td> </tr> <tr> <td>RU part name</td> <td>ШИМ</td> </tr> <tr> <td>Size:mm</td> <td></td> </tr> <tr> <td>Weight:kg</td> <td>0.75</td> </tr> <tr> <td>NO.</td> <td>NO.58-6</td> </tr> </table>		Part No.	12JS160T-1701125	CH part name	二轴档齿轮垫片	EN part name	Shim	RU part name	ШИМ	Size:mm		Weight:kg	0.75	NO.	NO.58-6			<table border="1"> <tr> <td>Part No.</td> <td>12JS160T-1701123</td> </tr> <tr> <td>CH part name</td> <td>二抽齿轮隔垫</td> </tr> <tr> <td>EN part name</td> <td>Washel</td> </tr> <tr> <td>RU part name</td> <td>распорка</td> </tr> <tr> <td>Size:mm</td> <td></td> </tr> <tr> <td>Weight:kg</td> <td>0.8</td> </tr> <tr> <td>NO.</td> <td>NO.58-5</td> </tr> </table>		Part No.	12JS160T-1701123	CH part name	二抽齿轮隔垫	EN part name	Washel	RU part name	распорка	Size:mm		Weight:kg	0.8	NO.	NO.58-5
				Part No.	12JS160T-1701125																														
				CH part name	二轴档齿轮垫片																														
				EN part name	Shim																														
				RU part name	ШИМ																														
				Size:mm																															
				Weight:kg	0.75																														
NO.	NO.58-6																																		
Part No.	12JS160T-1701123																																		
CH part name	二抽齿轮隔垫																																		
EN part name	Washel																																		
RU part name	распорка																																		
Size:mm																																			
Weight:kg	0.8																																		
NO.	NO.58-5																																		
Remarks:SHACMAN F3000 F2000				Remarks:SHACMAN F3000 F2000																															
		<table border="1"> <tr> <td>Part No.</td> <td>12JS160T-1701170</td> </tr> <tr> <td>CH part name</td> <td>一二档同步器</td> </tr> <tr> <td>EN part name</td> <td>Synchronizer assy.</td> </tr> <tr> <td>RU part name</td> <td>синхронизатор</td> </tr> <tr> <td>Size:mm</td> <td>200*200*50</td> </tr> <tr> <td>Weight:kg</td> <td>5.06</td> </tr> <tr> <td>NO.</td> <td>NO.58-7</td> </tr> </table>		Part No.	12JS160T-1701170	CH part name	一二档同步器	EN part name	Synchronizer assy.	RU part name	синхронизатор	Size:mm	200*200*50	Weight:kg	5.06	NO.	NO.58-7			<table border="1"> <tr> <td>Part No.</td> <td>JS130T-1701180</td> </tr> <tr> <td>CH part name</td> <td>三四档同步器</td> </tr> <tr> <td>EN part name</td> <td>Synchronizer assy.</td> </tr> <tr> <td>RU part name</td> <td>Синхронизатор</td> </tr> <tr> <td>Size:mm</td> <td>200*200*50</td> </tr> <tr> <td>Weight:kg</td> <td>5.06</td> </tr> <tr> <td>NO.</td> <td>NO.58-16</td> </tr> </table>		Part No.	JS130T-1701180	CH part name	三四档同步器	EN part name	Synchronizer assy.	RU part name	Синхронизатор	Size:mm	200*200*50	Weight:kg	5.06	NO.	NO.58-16
				Part No.	12JS160T-1701170																														
				CH part name	一二档同步器																														
				EN part name	Synchronizer assy.																														
				RU part name	синхронизатор																														
				Size:mm	200*200*50																														
				Weight:kg	5.06																														
NO.	NO.58-7																																		
Part No.	JS130T-1701180																																		
CH part name	三四档同步器																																		
EN part name	Synchronizer assy.																																		
RU part name	Синхронизатор																																		
Size:mm	200*200*50																																		
Weight:kg	5.06																																		
NO.	NO.58-16																																		
Remarks:SHACMAN F3000 F2000				Remarks:SHACMAN F3000 F2000																															







SHACMAN(1)

	<table border="1"> <tr><td>Part No.</td><td>12JS200T-1701048</td></tr> <tr><td>CH part name</td><td>中间轴</td></tr> <tr><td>EN part name</td><td>Intermediate axle</td></tr> <tr><td>RU part name</td><td>Промежуточный вал</td></tr> <tr><td>Size:mm</td><td>360*100</td></tr> <tr><td>Weight:kg</td><td>8.62</td></tr> <tr><td>NO.</td><td>NO.58-3E</td></tr> </table>	Part No.	12JS200T-1701048	CH part name	中间轴	EN part name	Intermediate axle	RU part name	Промежуточный вал	Size:mm	360*100	Weight:kg	8.62	NO.	NO.58-3E		<table border="1"> <tr><td>Part No.</td><td>JS100-1701051</td></tr> <tr><td>CH part name</td><td>中间轴</td></tr> <tr><td>EN part name</td><td>Intermediate axle</td></tr> <tr><td>RU part name</td><td>Промежуточный вал</td></tr> <tr><td>Size:mm</td><td>360*100</td></tr> <tr><td>Weight:kg</td><td>8.62</td></tr> <tr><td>NO.</td><td>NO.58-3E</td></tr> </table>	Part No.	JS100-1701051	CH part name	中间轴	EN part name	Intermediate axle	RU part name	Промежуточный вал	Size:mm	360*100	Weight:kg	8.62	NO.	NO.58-3E
Part No.	12JS200T-1701048																														
CH part name	中间轴																														
EN part name	Intermediate axle																														
RU part name	Промежуточный вал																														
Size:mm	360*100																														
Weight:kg	8.62																														
NO.	NO.58-3E																														
Part No.	JS100-1701051																														
CH part name	中间轴																														
EN part name	Intermediate axle																														
RU part name	Промежуточный вал																														
Size:mm	360*100																														
Weight:kg	8.62																														
NO.	NO.58-3E																														
Remarks:SHACMAN F3000 F2000 12JS160T-1701048		Remarks:SHACMAN F3000 F2000																													
	<table border="1"> <tr><td>Part No.</td><td>12JS200T-1701051</td></tr> <tr><td>CH part name</td><td>中间轴四档齿轮</td></tr> <tr><td>EN part name</td><td>Gear, 4rd speed</td></tr> <tr><td>RU part name</td><td>скорость света, 4rd</td></tr> <tr><td>Size:mm</td><td></td></tr> <tr><td>Weight:kg</td><td>4.3</td></tr> <tr><td>NO.</td><td>NO.58-5E</td></tr> </table>	Part No.	12JS200T-1701051	CH part name	中间轴四档齿轮	EN part name	Gear, 4rd speed	RU part name	скорость света, 4rd	Size:mm		Weight:kg	4.3	NO.	NO.58-5E		<table border="1"> <tr><td>Part No.</td><td>12JS200T-1701050</td></tr> <tr><td>CH part name</td><td>中间轴三档齿轮</td></tr> <tr><td>EN part name</td><td>Gear, 3rd speed</td></tr> <tr><td>RU part name</td><td>скорость света, 3rd</td></tr> <tr><td>Size:mm</td><td></td></tr> <tr><td>Weight:kg</td><td>4.2</td></tr> <tr><td>NO.</td><td>NO.58-4E</td></tr> </table>	Part No.	12JS200T-1701050	CH part name	中间轴三档齿轮	EN part name	Gear, 3rd speed	RU part name	скорость света, 3rd	Size:mm		Weight:kg	4.2	NO.	NO.58-4E
Part No.	12JS200T-1701051																														
CH part name	中间轴四档齿轮																														
EN part name	Gear, 4rd speed																														
RU part name	скорость света, 4rd																														
Size:mm																															
Weight:kg	4.3																														
NO.	NO.58-5E																														
Part No.	12JS200T-1701050																														
CH part name	中间轴三档齿轮																														
EN part name	Gear, 3rd speed																														
RU part name	скорость света, 3rd																														
Size:mm																															
Weight:kg	4.2																														
NO.	NO.58-4E																														
Remarks:SHACMAN F3000 F2000		Remarks:SHACMAN F3000 F2000 RT-11509C 16749																													
	<table border="1"> <tr><td>Part No.</td><td>12JS200T-1701052</td></tr> <tr><td>CH part name</td><td>中间轴五档齿轮</td></tr> <tr><td>EN part name</td><td>Gear, 5rd speed</td></tr> <tr><td>RU part name</td><td>скорость света, 5rd</td></tr> <tr><td>Size:mm</td><td></td></tr> <tr><td>Weight:kg</td><td>4.3</td></tr> <tr><td>NO.</td><td>NO.58-6E</td></tr> </table>	Part No.	12JS200T-1701052	CH part name	中间轴五档齿轮	EN part name	Gear, 5rd speed	RU part name	скорость света, 5rd	Size:mm		Weight:kg	4.3	NO.	NO.58-6E		<table border="1"> <tr><td>Part No.</td><td>12JS200T-1701056</td></tr> <tr><td>CH part name</td><td>中间轴传动齿轮</td></tr> <tr><td>EN part name</td><td>Drive gear</td></tr> <tr><td>RU part name</td><td>привода</td></tr> <tr><td>Size:mm</td><td></td></tr> <tr><td>Weight:kg</td><td>4.4</td></tr> <tr><td>NO.</td><td>NO.58-7E</td></tr> </table>	Part No.	12JS200T-1701056	CH part name	中间轴传动齿轮	EN part name	Drive gear	RU part name	привода	Size:mm		Weight:kg	4.4	NO.	NO.58-7E
Part No.	12JS200T-1701052																														
CH part name	中间轴五档齿轮																														
EN part name	Gear, 5rd speed																														
RU part name	скорость света, 5rd																														
Size:mm																															
Weight:kg	4.3																														
NO.	NO.58-6E																														
Part No.	12JS200T-1701056																														
CH part name	中间轴传动齿轮																														
EN part name	Drive gear																														
RU part name	привода																														
Size:mm																															
Weight:kg	4.4																														
NO.	NO.58-7E																														
Remarks: SHACMAN F3000 F2000		Remarks: SHACMAN F3000 F2000 RT-11509C 19552																													
	<table border="1"> <tr><td>Part No.</td><td>12JS160T-1707025</td></tr> <tr><td>CH part name</td><td>二轴轴承</td></tr> <tr><td>EN part name</td><td>Two shaft bearing</td></tr> <tr><td>RU part name</td><td>подшипник вторичного вала</td></tr> <tr><td>Size:mm</td><td></td></tr> <tr><td>Weight:kg</td><td>2.5</td></tr> <tr><td>NO.</td><td>NO.58-1</td></tr> </table>	Part No.	12JS160T-1707025	CH part name	二轴轴承	EN part name	Two shaft bearing	RU part name	подшипник вторичного вала	Size:mm		Weight:kg	2.5	NO.	NO.58-1		<table border="1"> <tr><td>Part No.</td><td>12JS200T-1701055</td></tr> <tr><td>CH part name</td><td>中间轴四方键</td></tr> <tr><td>EN part name</td><td>Gotter key</td></tr> <tr><td>RU part name</td><td>gotter ключ</td></tr> <tr><td>Size:mm</td><td></td></tr> <tr><td>Weight:kg</td><td>0.9</td></tr> <tr><td>NO.</td><td>NO.58-8E</td></tr> </table>	Part No.	12JS200T-1701055	CH part name	中间轴四方键	EN part name	Gotter key	RU part name	gotter ключ	Size:mm		Weight:kg	0.9	NO.	NO.58-8E
Part No.	12JS160T-1707025																														
CH part name	二轴轴承																														
EN part name	Two shaft bearing																														
RU part name	подшипник вторичного вала																														
Size:mm																															
Weight:kg	2.5																														
NO.	NO.58-1																														
Part No.	12JS200T-1701055																														
CH part name	中间轴四方键																														
EN part name	Gotter key																														
RU part name	gotter ключ																														
Size:mm																															
Weight:kg	0.9																														
NO.	NO.58-8E																														
Remarks:SHACMAN F3000 F2000		Remarks:SHACMAN F3000 F2000 RT-11509C 19673																													

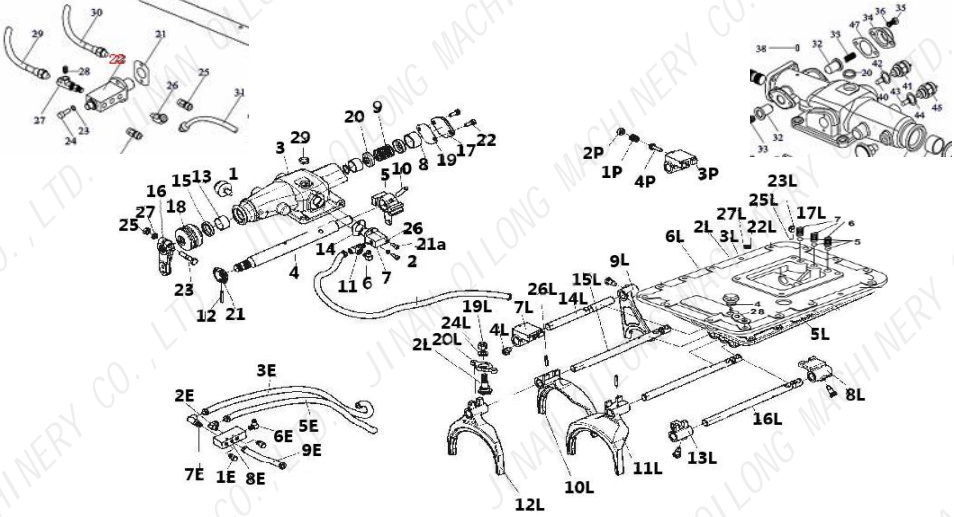





SHACMAN(1)

KD1003			KD1004		
	Part No.	12JS160T-1701121		Part No.	16756
	CH part name	二轴六角键		CH part name	二轴倒档齿轮
	EN part name	Key		EN part name	Gear , reverse speed
	RU part name	КЛЮЧ		RU part name	скорость света, отменить
	Size:mm			Size:mm	
	Weight:kg	0.1		Weight:kg	4.3
	Price:usd	NO.58-8b		Price:usd	NO.58-9
Remarks: SHACMAN F3000 F2000 RT-11509C 17109 12JS160T-1701121			Remarks: SHACMAN RT-11509C		
KD1005			KD1006		
	Part No.	12JS200T-1701110		Part No.	12JS160T-1701083
	CH part name	二轴倒档齿轮		CH part name	倒档中间齿轮
	EN part name	Gear , reverse speed		EN part name	Reverse gear
	RU part name	скорость света, отменить		RU part name	Idler gear/ промежуточная передача
	Size:mm	200*33		Size:mm	
	Weight:kg	3.46		Weight:kg	1.5
	NO.	NO.58-9		NO.	NO.58-2a
Remarks: SHACMAN			Remarks: SHACMAN RT-11509C 16757		
KD1007			KD1008		
	Part No.	JS100A-1702072		Part No.	JS100A-1702072
	CH part name	摆动拨头		CH part name	支轴承销
	EN part name	Sliding piece		EN part name	The bearing pin
	RU part name	набрать голову		RU part name	Палец подшипник ветвь
	Size:mm			Size:mm	
	Weight:kg	0.3		Weight:kg	0.32
	NO.	NO.A58-20L		NO.	NO.A58-2L
Remarks: SHACMAN			Remarks: SHACMAN		
KD1009			KD1010		
	Part No.	12JS160T-1702050		Part No.	12JS160T-1702015-1
	CH part name	倒挡导块		CH part name	变速箱上盖总成
	EN part name	Reverse guide block		EN part name	Top cover assembly
	RU part name	в руководстве блока вспяты		RU part name	верхнего покрытия Ассамблеи
	Size:mm	55*48*35		Size:mm	
	Weight:kg	0.4		Weight:kg	21
	NO.	NO.A58-7L		NO.	NO.A58-6L
Remarks: SHACMAN			Remarks: SHACMAN RT-11509C F99980-1		







SHACMAN(1)

DOUBLE H SHIFTING CONTROL/IVIECHANISIVI		NO.A58															
	KD1011																
			<table border="1"> <tr><td>Part No.</td><td>12JS160T-1702015</td></tr> <tr><td>CH part name</td><td>变速箱上盖</td></tr> <tr><td>EN part name</td><td>Shift cover assy</td></tr> <tr><td>RU part name</td><td>Верхняя крышка</td></tr> <tr><td>Size:mm</td><td>43*30*70</td></tr> <tr><td>Weight:kg</td><td>14</td></tr> <tr><td>NO.</td><td>NO.A58-6L</td></tr> </table>	Part No.	12JS160T-1702015	CH part name	变速箱上盖	EN part name	Shift cover assy	RU part name	Верхняя крышка	Size:mm	43*30*70	Weight:kg	14	NO.	NO.A58-6L
	Part No.	12JS160T-1702015															
	CH part name	变速箱上盖															
	EN part name	Shift cover assy															
	RU part name	Верхняя крышка															
	Size:mm	43*30*70															
	Weight:kg	14															
	NO.	NO.A58-6L															
	Remarks: SHACMAN RT-11509C F99980																
KD1012																	
		<table border="1"> <tr><td>Part No.</td><td>12JS160T-1702054</td></tr> <tr><td>CH part name</td><td>五六档导块</td></tr> <tr><td>EN part name</td><td>1/2 and 5/6speed assy</td></tr> <tr><td>RU part name</td><td>1 / 2 и 5 / 6speed астрид</td></tr> <tr><td>Size:mm</td><td>55*48*35</td></tr> <tr><td>Weight:kg</td><td>0.19</td></tr> <tr><td>NO.</td><td>NO.A58-8L</td></tr> </table>	Part No.	12JS160T-1702054	CH part name	五六档导块	EN part name	1/2 and 5/6speed assy	RU part name	1 / 2 и 5 / 6speed астрид	Size:mm	55*48*35	Weight:kg	0.19	NO.	NO.A58-8L	
Part No.	12JS160T-1702054																
CH part name	五六档导块																
EN part name	1/2 and 5/6speed assy																
RU part name	1 / 2 и 5 / 6speed астрид																
Size:mm	55*48*35																
Weight:kg	0.19																
NO.	NO.A58-8L																
Remarks:SHACMAN RT-11509C 16135																	
KD1013																	
	Part No.	12JS160T-1702055															
	CH part name	倒挡拨叉															
	EN part name	Reverse shift fork															
	RU part name	обратная передача вилка															
	Size:mm	185*100*65															
	Weight:kg	0.85															
	NO.	NO.A58-9L															
Remarks: SHACMAN																	
KD1014																	
	Part No.	12JS160T-1702056															
	CH part name	一二档拨叉															
	EN part name	Shift fork 1/2 speed															
	RU part name	Вилка переключения 1-й и 2-й передач															
	Size:mm	183*93*160															
	Weight:kg	1.23															
	NO.	NO.A58-10L															
Remarks: SHACMAN RT-11509C 16135 JS100A-1702055																	
KD1015																	
	Part No.	12JS160T-1702057															
	CH part name	三四档拨叉															
	EN part name	3/4 gear shift fork															
	RU part name	Вилка переключения 3-й и 4-й передач															
	Size:mm	200*175*83															
	Weight:kg	1.55															
	NO.	NO.A58-11L															
Remarks: SHACMAN RT-11509C 16136 JS100A-1702056																	
KD1016																	
	Part No.	12JS160T-1702058															
	CH part name	五六档拨叉															
	EN part name	5/6 gear shift fork															
	RU part name	Вилка переключения 5-й и 6-й передач															
	Size:mm																
	Weight:kg	1.23															
	NO.	NO.A58-12L															
Remarks: SHACMAN																	

SHACMAN(1)

	<table border="1"> <tr><td>Part No.</td><td>12JS160T-1702063</td></tr> <tr><td>CH part name</td><td>倒挡拨叉轴</td></tr> <tr><td>EN part name</td><td>Reverse shift fork shaft</td></tr> <tr><td>RU part name</td><td>реверсивный вал вилка</td></tr> <tr><td>Size:mm</td><td></td></tr> <tr><td>Weight:kg</td><td>1.2</td></tr> <tr><td>NO.</td><td>NO.A58-14L</td></tr> </table>	Part No.	12JS160T-1702063	CH part name	倒挡拨叉轴	EN part name	Reverse shift fork shaft	RU part name	реверсивный вал вилка	Size:mm		Weight:kg	1.2	NO.	NO.A58-14L		<table border="1"> <tr><td>Part No.</td><td>12JS160T-1702059</td></tr> <tr><td>CH part name</td><td>五六当换挡导块</td></tr> <tr><td>EN part name</td><td>B lock,5/6 speed</td></tr> <tr><td>RU part name</td><td>в замок, 5 / 6, скорость</td></tr> <tr><td>Size:mm</td><td></td></tr> <tr><td>Weight:kg</td><td>0.189</td></tr> <tr><td>NO.</td><td>NO.A58-13L</td></tr> </table>	Part No.	12JS160T-1702059	CH part name	五六当换挡导块	EN part name	B lock,5/6 speed	RU part name	в замок, 5 / 6, скорость	Size:mm		Weight:kg	0.189	NO.	NO.A58-13L
Part No.	12JS160T-1702063																														
CH part name	倒挡拨叉轴																														
EN part name	Reverse shift fork shaft																														
RU part name	реверсивный вал вилка																														
Size:mm																															
Weight:kg	1.2																														
NO.	NO.A58-14L																														
Part No.	12JS160T-1702059																														
CH part name	五六当换挡导块																														
EN part name	B lock,5/6 speed																														
RU part name	в замок, 5 / 6, скорость																														
Size:mm																															
Weight:kg	0.189																														
NO.	NO.A58-13L																														
Remarks: SHACMAN RT-11509C 16132		Remarks: SHACMAN F3000 F2000 RT-11509C F99588																													
	<table border="1"> <tr><td>Part No.</td><td>12JS160T-1702064</td></tr> <tr><td>CH part name</td><td>1234档拨叉轴</td></tr> <tr><td>EN part name</td><td>Shaft 3/4and1/2speed</td></tr> <tr><td>RU part name</td><td>вал, 3 / 4and1 / 2speed</td></tr> <tr><td>Size:mm</td><td></td></tr> <tr><td>Weight:kg</td><td>1.2</td></tr> <tr><td>NO.</td><td>NO.A58-15L</td></tr> </table>	Part No.	12JS160T-1702064	CH part name	1234档拨叉轴	EN part name	Shaft 3/4and1/2speed	RU part name	вал, 3 / 4and1 / 2speed	Size:mm		Weight:kg	1.2	NO.	NO.A58-15L		<table border="1"> <tr><td>Part No.</td><td>018643</td></tr> <tr><td>CH part name</td><td>3-4和7-8档拨叉轴</td></tr> <tr><td>EN part name</td><td>Shaft 3/4and7/8speed</td></tr> <tr><td>RU part name</td><td>вал, 3 / 4and7 / 8speed</td></tr> <tr><td>Size:mm</td><td></td></tr> <tr><td>Weight:kg</td><td>1.23</td></tr> <tr><td>NO.</td><td>NO.A58-15L</td></tr> </table>	Part No.	018643	CH part name	3-4和7-8档拨叉轴	EN part name	Shaft 3/4and7/8speed	RU part name	вал, 3 / 4and7 / 8speed	Size:mm		Weight:kg	1.23	NO.	NO.A58-15L
Part No.	12JS160T-1702064																														
CH part name	1234档拨叉轴																														
EN part name	Shaft 3/4and1/2speed																														
RU part name	вал, 3 / 4and1 / 2speed																														
Size:mm																															
Weight:kg	1.2																														
NO.	NO.A58-15L																														
Part No.	018643																														
CH part name	3-4和7-8档拨叉轴																														
EN part name	Shaft 3/4and7/8speed																														
RU part name	вал, 3 / 4and7 / 8speed																														
Size:mm																															
Weight:kg	1.23																														
NO.	NO.A58-15L																														
Remarks: SHACMAN		Remarks: SHACMAN RT-11509C																													
	<table border="1"> <tr><td>Part No.</td><td>12JS160T-1702066</td></tr> <tr><td>CH part name</td><td>五六档拨叉轴</td></tr> <tr><td>EN part name</td><td>Shaft 5.and 6.speed</td></tr> <tr><td>RU part name</td><td>вал, 5.and 6.speed</td></tr> <tr><td>Size:mm</td><td></td></tr> <tr><td>Weight:kg</td><td>1.23</td></tr> <tr><td>NO.</td><td>NO.A58-16L</td></tr> </table>	Part No.	12JS160T-1702066	CH part name	五六档拨叉轴	EN part name	Shaft 5.and 6.speed	RU part name	вал, 5.and 6.speed	Size:mm		Weight:kg	1.23	NO.	NO.A58-16L		<table border="1"> <tr><td>Part No.</td><td>F96085/F96084</td></tr> <tr><td>CH part name</td><td>弹簧</td></tr> <tr><td>EN part name</td><td>Spring</td></tr> <tr><td>RU part name</td><td>Пружина</td></tr> <tr><td>Size:mm</td><td>40*11</td></tr> <tr><td>Weight:kg</td><td>0.01</td></tr> <tr><td>NO.</td><td>NO.A58-6-7</td></tr> </table>	Part No.	F96085/F96084	CH part name	弹簧	EN part name	Spring	RU part name	Пружина	Size:mm	40*11	Weight:kg	0.01	NO.	NO.A58-6-7
Part No.	12JS160T-1702066																														
CH part name	五六档拨叉轴																														
EN part name	Shaft 5.and 6.speed																														
RU part name	вал, 5.and 6.speed																														
Size:mm																															
Weight:kg	1.23																														
NO.	NO.A58-16L																														
Part No.	F96085/F96084																														
CH part name	弹簧																														
EN part name	Spring																														
RU part name	Пружина																														
Size:mm	40*11																														
Weight:kg	0.01																														
NO.	NO.A58-6-7																														
Remarks: SHACMAN		Remarks: SHACMAN RT-11509C 12JS160T																													
	<table border="1"> <tr><td>Part No.</td><td>12JS160T-1703015-1</td></tr> <tr><td>CH part name</td><td>双H操纵装置总成</td></tr> <tr><td>EN part name</td><td>Double H operating mechanism assy.</td></tr> <tr><td>RU part name</td><td>Механизм переключения передач низшей и высшей зоны</td></tr> <tr><td>Size:mm</td><td>435*177*70</td></tr> <tr><td>Weight:kg</td><td>10.5</td></tr> <tr><td>NO.</td><td>NO.A58-3</td></tr> </table>	Part No.	12JS160T-1703015-1	CH part name	双H操纵装置总成	EN part name	Double H operating mechanism assy.	RU part name	Механизм переключения передач низшей и высшей зоны	Size:mm	435*177*70	Weight:kg	10.5	NO.	NO.A58-3		<table border="1"> <tr><td>Part No.</td><td>12JS160T-1703010</td></tr> <tr><td>CH part name</td><td>双H总成</td></tr> <tr><td>EN part name</td><td>Double H operating mechanism assy.</td></tr> <tr><td>RU part name</td><td>Механизм переключения передач низшей и высше</td></tr> <tr><td>Size:mm</td><td>435*177*70</td></tr> <tr><td>Weight:kg</td><td>10.5</td></tr> <tr><td>NO.</td><td>NO.A58-3</td></tr> </table>	Part No.	12JS160T-1703010	CH part name	双H总成	EN part name	Double H operating mechanism assy.	RU part name	Механизм переключения передач низшей и высше	Size:mm	435*177*70	Weight:kg	10.5	NO.	NO.A58-3
Part No.	12JS160T-1703015-1																														
CH part name	双H操纵装置总成																														
EN part name	Double H operating mechanism assy.																														
RU part name	Механизм переключения передач низшей и высшей зоны																														
Size:mm	435*177*70																														
Weight:kg	10.5																														
NO.	NO.A58-3																														
Part No.	12JS160T-1703010																														
CH part name	双H总成																														
EN part name	Double H operating mechanism assy.																														
RU part name	Механизм переключения передач низшей и высше																														
Size:mm	435*177*70																														
Weight:kg	10.5																														
NO.	NO.A58-3																														
Remarks: SHACMAN F3000 F2000		Remarks: SHACMAN F3000 F2000																													



SHACMAN(1)

	<p>KD1025</p> <table border="1"> <tr><td>Part No.</td><td>JS100-1702051-3</td></tr> <tr><td>CH part name</td><td>双H操纵装置(双杆)右</td></tr> <tr><td>EN part name</td><td>Double H operating mechanism assy.</td></tr> <tr><td>RU part name</td><td>Двойной H манипулятор</td></tr> <tr><td>Size:mm</td><td>435*177*70</td></tr> <tr><td>Weight:kg</td><td>10.5</td></tr> <tr><td>NO.</td><td>NO.A58-3</td></tr> </table>	Part No.	JS100-1702051-3	CH part name	双H操纵装置(双杆)右	EN part name	Double H operating mechanism assy.	RU part name	Двойной H манипулятор	Size:mm	435*177*70	Weight:kg	10.5	NO.	NO.A58-3		<p>KD1026</p> <table border="1"> <tr><td>Part No.</td><td>A-C03001</td></tr> <tr><td>CH part name</td><td>双H操纵装置总成</td></tr> <tr><td>EN part name</td><td>Double H operating mechanism assy.</td></tr> <tr><td>RU part name</td><td>Механизм переключения передач низшей и высшей зоны</td></tr> <tr><td>Size:mm</td><td>435*177*70</td></tr> <tr><td>Weight:kg</td><td>10.5</td></tr> <tr><td>NO.</td><td>NO.A58-3</td></tr> </table>	Part No.	A-C03001	CH part name	双H操纵装置总成	EN part name	Double H operating mechanism assy.	RU part name	Механизм переключения передач низшей и высшей зоны	Size:mm	435*177*70	Weight:kg	10.5	NO.	NO.A58-3
Part No.	JS100-1702051-3																														
CH part name	双H操纵装置(双杆)右																														
EN part name	Double H operating mechanism assy.																														
RU part name	Двойной H манипулятор																														
Size:mm	435*177*70																														
Weight:kg	10.5																														
NO.	NO.A58-3																														
Part No.	A-C03001																														
CH part name	双H操纵装置总成																														
EN part name	Double H operating mechanism assy.																														
RU part name	Механизм переключения передач низшей и высшей зоны																														
Size:mm	435*177*70																														
Weight:kg	10.5																														
NO.	NO.A58-3																														
Remarks: SHACMAN F3000 F2000		Remarks: SHACMAN RT-11509C																													
	<p>KD1027</p> <table border="1"> <tr><td>Part No.</td><td>F96194</td></tr> <tr><td>CH part name</td><td>操纵装置壳体</td></tr> <tr><td>EN part name</td><td>Housing</td></tr> <tr><td>RU part name</td><td>Корпус</td></tr> <tr><td>Size:mm</td><td>360*180*75</td></tr> <tr><td>Weight:kg</td><td>6</td></tr> <tr><td>NO.</td><td>NO.A58-3</td></tr> </table>	Part No.	F96194	CH part name	操纵装置壳体	EN part name	Housing	RU part name	Корпус	Size:mm	360*180*75	Weight:kg	6	NO.	NO.A58-3		<p>KD1028</p> <table border="1"> <tr><td>Part No.</td><td>12JS160T-1703015</td></tr> <tr><td>CH part name</td><td>操纵装置壳体</td></tr> <tr><td>EN part name</td><td>Housing</td></tr> <tr><td>RU part name</td><td>Корпус</td></tr> <tr><td>Size:mm</td><td>360*180*75</td></tr> <tr><td>Weight:kg</td><td>6</td></tr> <tr><td>NO.</td><td>NO.A58-3</td></tr> </table>	Part No.	12JS160T-1703015	CH part name	操纵装置壳体	EN part name	Housing	RU part name	Корпус	Size:mm	360*180*75	Weight:kg	6	NO.	NO.A58-3
Part No.	F96194																														
CH part name	操纵装置壳体																														
EN part name	Housing																														
RU part name	Корпус																														
Size:mm	360*180*75																														
Weight:kg	6																														
NO.	NO.A58-3																														
Part No.	12JS160T-1703015																														
CH part name	操纵装置壳体																														
EN part name	Housing																														
RU part name	Корпус																														
Size:mm	360*180*75																														
Weight:kg	6																														
NO.	NO.A58-3																														
Remarks: SHACMAN RT-11509C		Remarks: SHACMAN																													
	<p>KD1029</p> <table border="1"> <tr><td>Part No.</td><td>15276</td></tr> <tr><td>CH part name</td><td>通气塞</td></tr> <tr><td>EN part name</td><td>Air vent plug</td></tr> <tr><td>RU part name</td><td>вытяжка пробка</td></tr> <tr><td>Size:mm</td><td></td></tr> <tr><td>Weight:kg</td><td>0.1</td></tr> <tr><td>NO.</td><td>NO.A58-1</td></tr> </table>	Part No.	15276	CH part name	通气塞	EN part name	Air vent plug	RU part name	вытяжка пробка	Size:mm		Weight:kg	0.1	NO.	NO.A58-1		<p>KD1030</p> <table border="1"> <tr><td>Part No.</td><td>12JS160T-1703017</td></tr> <tr><td>CH part name</td><td>横向换挡杆</td></tr> <tr><td>EN part name</td><td>Shift lever</td></tr> <tr><td>RU part name</td><td>Рычаг переключения</td></tr> <tr><td>Size:mm</td><td>387*30*20</td></tr> <tr><td>Weight:kg</td><td>1.98</td></tr> <tr><td>NO.</td><td>NO.A58-4</td></tr> </table>	Part No.	12JS160T-1703017	CH part name	横向换挡杆	EN part name	Shift lever	RU part name	Рычаг переключения	Size:mm	387*30*20	Weight:kg	1.98	NO.	NO.A58-4
Part No.	15276																														
CH part name	通气塞																														
EN part name	Air vent plug																														
RU part name	вытяжка пробка																														
Size:mm																															
Weight:kg	0.1																														
NO.	NO.A58-1																														
Part No.	12JS160T-1703017																														
CH part name	横向换挡杆																														
EN part name	Shift lever																														
RU part name	Рычаг переключения																														
Size:mm	387*30*20																														
Weight:kg	1.98																														
NO.	NO.A58-4																														
Remarks: SHACMAN		Remarks: SHACMAN																													
	<p>KD1031</p> <table border="1"> <tr><td>Part No.</td><td>F99679</td></tr> <tr><td>CH part name</td><td>横向换挡杆</td></tr> <tr><td>EN part name</td><td>Shift lever</td></tr> <tr><td>RU part name</td><td>Рычаг переключения</td></tr> <tr><td>Size:mm</td><td>387*30*20</td></tr> <tr><td>Weight:kg</td><td>1.98</td></tr> <tr><td>NO.</td><td>NO.A58-4</td></tr> </table>	Part No.	F99679	CH part name	横向换挡杆	EN part name	Shift lever	RU part name	Рычаг переключения	Size:mm	387*30*20	Weight:kg	1.98	NO.	NO.A58-4		<p>KD1032</p> <table border="1"> <tr><td>Part No.</td><td>12JS160T-1703018</td></tr> <tr><td>CH part name</td><td>拨头</td></tr> <tr><td>EN part name</td><td>Finger</td></tr> <tr><td>RU part name</td><td>палец</td></tr> <tr><td>Size:mm</td><td></td></tr> <tr><td>Weight:kg</td><td>0.43</td></tr> <tr><td>NO.</td><td>NO.A58-5</td></tr> </table>	Part No.	12JS160T-1703018	CH part name	拨头	EN part name	Finger	RU part name	палец	Size:mm		Weight:kg	0.43	NO.	NO.A58-5
Part No.	F99679																														
CH part name	横向换挡杆																														
EN part name	Shift lever																														
RU part name	Рычаг переключения																														
Size:mm	387*30*20																														
Weight:kg	1.98																														
NO.	NO.A58-4																														
Part No.	12JS160T-1703018																														
CH part name	拨头																														
EN part name	Finger																														
RU part name	палец																														
Size:mm																															
Weight:kg	0.43																														
NO.	NO.A58-5																														
Remarks: SHACMAN RT-11509C		Remarks: SHACMAN RT-11509C F99585																													

SHACMAN(1)

	<p>KD1033</p> <table border="1"> <tr><td>Part No.</td><td>12JS160T-1703022</td></tr> <tr><td>CH part name</td><td>气路控制阀</td></tr> <tr><td>EN part name</td><td>air valve</td></tr> <tr><td>RU part name</td><td>воздушный клапан</td></tr> <tr><td>Size:mm</td><td></td></tr> <tr><td>Weight:kg</td><td>0.15</td></tr> <tr><td>NO.</td><td>NO.A58-7</td></tr> </table>	Part No.	12JS160T-1703022	CH part name	气路控制阀	EN part name	air valve	RU part name	воздушный клапан	Size:mm		Weight:kg	0.15	NO.	NO.A58-7		<p>KD1034</p> <table border="1"> <tr><td>Part No.</td><td>F91444</td></tr> <tr><td>CH part name</td><td>油封</td></tr> <tr><td>EN part name</td><td>Oil seal</td></tr> <tr><td>RU part name</td><td>нефть печать</td></tr> <tr><td>Size:mm</td><td>30*10</td></tr> <tr><td>Weight:kg</td><td>0.01</td></tr> <tr><td>NO.</td><td>NO.A58-15</td></tr> </table>	Part No.	F91444	CH part name	油封	EN part name	Oil seal	RU part name	нефть печать	Size:mm	30*10	Weight:kg	0.01	NO.	NO.A58-15
Part No.	12JS160T-1703022																														
CH part name	气路控制阀																														
EN part name	air valve																														
RU part name	воздушный клапан																														
Size:mm																															
Weight:kg	0.15																														
NO.	NO.A58-7																														
Part No.	F91444																														
CH part name	油封																														
EN part name	Oil seal																														
RU part name	нефть печать																														
Size:mm	30*10																														
Weight:kg	0.01																														
NO.	NO.A58-15																														
Remarks: SHACMAN F3000 F2000		Remarks: SHACMAN 12JS160T 12JS200 RT-11509C																													
	<p>KD1035</p> <table border="1"> <tr><td>Part No.</td><td>F99681</td></tr> <tr><td>CH part name</td><td>控制块</td></tr> <tr><td>EN part name</td><td>Control block</td></tr> <tr><td>RU part name</td><td>контроль блок</td></tr> <tr><td>Size:mm</td><td></td></tr> <tr><td>Weight:kg</td><td>0.12</td></tr> <tr><td>NO.</td><td>NO.A58-21</td></tr> </table>	Part No.	F99681	CH part name	控制块	EN part name	Control block	RU part name	контроль блок	Size:mm		Weight:kg	0.12	NO.	NO.A58-21		<p>KD1036</p> <table border="1"> <tr><td>Part No.</td><td>F99983</td></tr> <tr><td>CH part name</td><td>压缩弹簧</td></tr> <tr><td>EN part name</td><td>Spring</td></tr> <tr><td>RU part name</td><td>весной</td></tr> <tr><td>Size:mm</td><td></td></tr> <tr><td>Weight:kg</td><td>0.03</td></tr> <tr><td>NO.</td><td>NO.A58-9</td></tr> </table>	Part No.	F99983	CH part name	压缩弹簧	EN part name	Spring	RU part name	весной	Size:mm		Weight:kg	0.03	NO.	NO.A58-9
Part No.	F99681																														
CH part name	控制块																														
EN part name	Control block																														
RU part name	контроль блок																														
Size:mm																															
Weight:kg	0.12																														
NO.	NO.A58-21																														
Part No.	F99983																														
CH part name	压缩弹簧																														
EN part name	Spring																														
RU part name	весной																														
Size:mm																															
Weight:kg	0.03																														
NO.	NO.A58-9																														
Remarks: SHACMAN		Remarks: SHACMAN RT-11509C 12JS160T-1703027																													
	<p>KD1037</p> <table border="1"> <tr><td>Part No.</td><td>F96035</td></tr> <tr><td>CH part name</td><td>LRC换挡臂</td></tr> <tr><td>EN part name</td><td>LRC shift arm</td></tr> <tr><td>RU part name</td><td>Рычаг переключения передач LRC</td></tr> <tr><td>Size:mm</td><td>118*40*25</td></tr> <tr><td>Weight:kg</td><td>0.37</td></tr> <tr><td>NO.</td><td>NO.A58-16</td></tr> </table>	Part No.	F96035	CH part name	LRC换挡臂	EN part name	LRC shift arm	RU part name	Рычаг переключения передач LRC	Size:mm	118*40*25	Weight:kg	0.37	NO.	NO.A58-16		<p>KD1038</p> <table border="1"> <tr><td>Part No.</td><td>F99669</td></tr> <tr><td>CH part name</td><td>防尘套</td></tr> <tr><td>EN part name</td><td>Dust wrapper</td></tr> <tr><td>RU part name</td><td>обёртка от пыли</td></tr> <tr><td>Size:mm</td><td></td></tr> <tr><td>Weight:kg</td><td>0.02</td></tr> <tr><td>NO.</td><td>NO.A58-18</td></tr> </table>	Part No.	F99669	CH part name	防尘套	EN part name	Dust wrapper	RU part name	обёртка от пыли	Size:mm		Weight:kg	0.02	NO.	NO.A58-18
Part No.	F96035																														
CH part name	LRC换挡臂																														
EN part name	LRC shift arm																														
RU part name	Рычаг переключения передач LRC																														
Size:mm	118*40*25																														
Weight:kg	0.37																														
NO.	NO.A58-16																														
Part No.	F99669																														
CH part name	防尘套																														
EN part name	Dust wrapper																														
RU part name	обёртка от пыли																														
Size:mm																															
Weight:kg	0.02																														
NO.	NO.A58-18																														
Remarks: SHACMAN		Remarks: SHACMAN																													
	<p>KD1039</p> <table border="1"> <tr><td>Part No.</td><td>55512</td></tr> <tr><td>CH part name</td><td>双H气管</td></tr> <tr><td>EN part name</td><td>Air pipe</td></tr> <tr><td>RU part name</td><td>Воздушная трубка</td></tr> <tr><td>Size:mm</td><td>770*15</td></tr> <tr><td>Weight:kg</td><td>0.26</td></tr> <tr><td>NO.</td><td>NO.A58-3</td></tr> </table>	Part No.	55512	CH part name	双H气管	EN part name	Air pipe	RU part name	Воздушная трубка	Size:mm	770*15	Weight:kg	0.26	NO.	NO.A58-3		<p>KD1040</p> <table border="1"> <tr><td>Part No.</td><td>DZ9100360070</td></tr> <tr><td>CH part name</td><td>七通分气接头</td></tr> <tr><td>EN part name</td><td>Seven vent connections</td></tr> <tr><td>RU part name</td><td>Семь разряда</td></tr> <tr><td>Size:mm</td><td></td></tr> <tr><td>Weight:kg</td><td>0.34</td></tr> <tr><td>NO.</td><td>NO.A58-8</td></tr> </table>	Part No.	DZ9100360070	CH part name	七通分气接头	EN part name	Seven vent connections	RU part name	Семь разряда	Size:mm		Weight:kg	0.34	NO.	NO.A58-8
Part No.	55512																														
CH part name	双H气管																														
EN part name	Air pipe																														
RU part name	Воздушная трубка																														
Size:mm	770*15																														
Weight:kg	0.26																														
NO.	NO.A58-3																														
Part No.	DZ9100360070																														
CH part name	七通分气接头																														
EN part name	Seven vent connections																														
RU part name	Семь разряда																														
Size:mm																															
Weight:kg	0.34																														
NO.	NO.A58-8																														
Remarks: SHACMAN F3000 F2000 55511		Remarks: SHACMAN																													

SHACMAN(1)

	<table border="1"> <tr><td>Part No.</td><td>55518</td></tr> <tr><td>CH part name</td><td>双H气管</td></tr> <tr><td>EN part name</td><td>Air pipe</td></tr> <tr><td>RU part name</td><td>Воздушная трубка</td></tr> <tr><td>Size:mm</td><td>770*15</td></tr> <tr><td>Weight:kg</td><td>0.26</td></tr> <tr><td>NO.</td><td>NO.A58-4</td></tr> </table>	Part No.	55518	CH part name	双H气管	EN part name	Air pipe	RU part name	Воздушная трубка	Size:mm	770*15	Weight:kg	0.26	NO.	NO.A58-4		<table border="1"> <tr><td>Part No.</td><td>55523</td></tr> <tr><td>CH part name</td><td>双H气管</td></tr> <tr><td>EN part name</td><td>Air pipe</td></tr> <tr><td>RU part name</td><td>Воздушная трубка</td></tr> <tr><td>Size:mm</td><td>770*15</td></tr> <tr><td>Weight:kg</td><td>0.26</td></tr> <tr><td>NO.</td><td>NO.A58-5</td></tr> </table>	Part No.	55523	CH part name	双H气管	EN part name	Air pipe	RU part name	Воздушная трубка	Size:mm	770*15	Weight:kg	0.26	NO.	NO.A58-5
Part No.	55518																														
CH part name	双H气管																														
EN part name	Air pipe																														
RU part name	Воздушная трубка																														
Size:mm	770*15																														
Weight:kg	0.26																														
NO.	NO.A58-4																														
Part No.	55523																														
CH part name	双H气管																														
EN part name	Air pipe																														
RU part name	Воздушная трубка																														
Size:mm	770*15																														
Weight:kg	0.26																														
NO.	NO.A58-5																														
Remarks: SHACMAN F3000 F2000		Remarks: SHACMAN F3000 F2000 55521																													
	<table border="1"> <tr><td>Part No.</td><td>F99660</td></tr> <tr><td>CH part name</td><td>双H阀</td></tr> <tr><td>EN part name</td><td>Double H valve</td></tr> <tr><td>RU part name</td><td>двойной h клапан</td></tr> <tr><td>Size:mm</td><td>150*50*45</td></tr> <tr><td>Weight:kg</td><td>0.32</td></tr> <tr><td>NO.</td><td>NO.A58-22</td></tr> </table>	Part No.	F99660	CH part name	双H阀	EN part name	Double H valve	RU part name	двойной h клапан	Size:mm	150*50*45	Weight:kg	0.32	NO.	NO.A58-22		<table border="1"> <tr><td>Part No.</td><td>12JS160T-1703052</td></tr> <tr><td>CH part name</td><td>单H阀</td></tr> <tr><td>EN part name</td><td>air valve</td></tr> <tr><td>RU part name</td><td>воздушный клапан</td></tr> <tr><td>Size:mm</td><td></td></tr> <tr><td>Weight:kg</td><td>0.15</td></tr> <tr><td>NO.</td><td>NO.A58-8</td></tr> </table>	Part No.	12JS160T-1703052	CH part name	单H阀	EN part name	air valve	RU part name	воздушный клапан	Size:mm		Weight:kg	0.15	NO.	NO.A58-8
Part No.	F99660																														
CH part name	双H阀																														
EN part name	Double H valve																														
RU part name	двойной h клапан																														
Size:mm	150*50*45																														
Weight:kg	0.32																														
NO.	NO.A58-22																														
Part No.	12JS160T-1703052																														
CH part name	单H阀																														
EN part name	air valve																														
RU part name	воздушный клапан																														
Size:mm																															
Weight:kg	0.15																														
NO.	NO.A58-8																														
Remarks:SHACMAN F3000 F2000 RT-11509C		Remarks:SHACMAN F3000 F2000																													
	<table border="1"> <tr><td>Part No.</td><td>F99660-A</td></tr> <tr><td>CH part name</td><td>双H阀总成</td></tr> <tr><td>EN part name</td><td>Double H valve</td></tr> <tr><td>RU part name</td><td>двойной h клапан</td></tr> <tr><td>Size:mm</td><td></td></tr> <tr><td>Weight:kg</td><td>0.95</td></tr> <tr><td>NO.</td><td>NO.A58-22</td></tr> </table>	Part No.	F99660-A	CH part name	双H阀总成	EN part name	Double H valve	RU part name	двойной h клапан	Size:mm		Weight:kg	0.95	NO.	NO.A58-22		<table border="1"> <tr><td>Part No.</td><td>79100710068</td></tr> <tr><td>CH part name</td><td>倒挡开关</td></tr> <tr><td>EN part name</td><td>Reverse gear switch</td></tr> <tr><td>RU part name</td><td>Выключатель задней передачи</td></tr> <tr><td>Size:mm</td><td>51*29</td></tr> <tr><td>Weight:kg</td><td>0.085</td></tr> <tr><td>NO.</td><td>NO.A58-45</td></tr> </table>	Part No.	79100710068	CH part name	倒挡开关	EN part name	Reverse gear switch	RU part name	Выключатель задней передачи	Size:mm	51*29	Weight:kg	0.085	NO.	NO.A58-45
Part No.	F99660-A																														
CH part name	双H阀总成																														
EN part name	Double H valve																														
RU part name	двойной h клапан																														
Size:mm																															
Weight:kg	0.95																														
NO.	NO.A58-22																														
Part No.	79100710068																														
CH part name	倒挡开关																														
EN part name	Reverse gear switch																														
RU part name	Выключатель задней передачи																														
Size:mm	51*29																														
Weight:kg	0.085																														
NO.	NO.A58-45																														
Remarks:SHACMAN F3000 F2000 RT-11509C		Remarks:SHACMAN F3000 F2000 RT-11509C																													
	<table border="1"> <tr><td>Part No.</td><td>0068-1</td></tr> <tr><td>CH part name</td><td>倒档开关</td></tr> <tr><td>EN part name</td><td>Reverse gear switch</td></tr> <tr><td>RU part name</td><td>Выключатель задней передачи</td></tr> <tr><td>Size:mm</td><td></td></tr> <tr><td>Weight:kg</td><td>0.09</td></tr> <tr><td>NO.</td><td>NO.A58-45</td></tr> </table>	Part No.	0068-1	CH part name	倒档开关	EN part name	Reverse gear switch	RU part name	Выключатель задней передачи	Size:mm		Weight:kg	0.09	NO.	NO.A58-45		<table border="1"> <tr><td>Part No.</td><td>99012710041</td></tr> <tr><td>CH part name</td><td>空挡开关</td></tr> <tr><td>EN part name</td><td>Neutral switch</td></tr> <tr><td>RU part name</td><td>Выключатель нейтрального положения</td></tr> <tr><td>Size:mm</td><td>53*22</td></tr> <tr><td>Weight:kg</td><td>0.08</td></tr> <tr><td>NO.</td><td>NO.A58-41</td></tr> </table>	Part No.	99012710041	CH part name	空挡开关	EN part name	Neutral switch	RU part name	Выключатель нейтрального положения	Size:mm	53*22	Weight:kg	0.08	NO.	NO.A58-41
Part No.	0068-1																														
CH part name	倒档开关																														
EN part name	Reverse gear switch																														
RU part name	Выключатель задней передачи																														
Size:mm																															
Weight:kg	0.09																														
NO.	NO.A58-45																														
Part No.	99012710041																														
CH part name	空挡开关																														
EN part name	Neutral switch																														
RU part name	Выключатель нейтрального положения																														
Size:mm	53*22																														
Weight:kg	0.08																														
NO.	NO.A58-41																														
Remarks: SHACMAN F3000 F2000		Remarks: SHACMAN F3000 F2000 RT-11509C																													

SHACMAN(1)

	<p>Part No. 0041-3 CH part name 空挡开关 EN part name Neutral switch RU part name Выключатель нейтрального положения Size:mm Weight:kg 0.09 NO. NO.A58-41</p>	<p>KD1050</p> 	<p>Part No. 12JS160T-1707010-7 CH part name 副箱总成G5570 EN part name Vice box assembly RU part name Заместитель ящик Ассамблеи Size:mm 550*230*25 Weight:kg 90.6 NO. NO.59</p>
Remarks: SHACMAN F3000 F2000 F99975 JSD220-1707015		Remarks: SHACMAN F3000 F2000 12JS200	
<p>KD1051</p> 	<p>Part No. JSD180-1707015 CH part name 后盖壳体 EN part name Housing RU part name Крышка задняя коробки передач Size:mm 495*340*63 Weight:kg 15 NO. NO.59-24</p>	<p>KD1052</p> 	<p>Part No. 9JS180 CH part name 副箱总成 EN part name Vice box assembly RU part name Заместитель ящик Ассамблеи Size:mm 550*230*25 Weight:kg 90.6 NO. NO.59</p>
Remarks: SHACMAN 10JSD160 10JSD180 12JS160T, 12JS160TA 12JS200T		Remarks: SHACMAN F3000 F2000	
<p>KD1053</p> 	<p>Part No. F99975 CH part name 后盖壳体 EN part name Housing RU part name Крышка задняя коробки передач Size:mm 495*340*63 Weight:kg 14.61 NO. NO.59-24</p>	<p>KD1054</p> 	<p>Part No. 10JS160-1707052 CH part name 加长中间轴盖 EN part name Cover bearing RU part name покрытия с Size:mm Weight:kg 0.6 NO. NO.59-3</p>
Remarks: SHACMAN 11509C 9JS135		Remarks: SHACMAN F3000 F2000 JS180-1707052 17376	
<p>KD1055</p> 	<p>Part No. RTD-11609A-1707015 CH part name 后盖壳体 EN part name Housing RU part name Крышка задняя коробки передач Size:mm Weight:kg 14.7 NO. NO.59-24</p>	<p>KD1056</p> 	<p>Part No. 16775 CH part name 副箱拨叉 EN part name Sub-gearbox shift fork RU part name Вилка делителя передач Size:mm 195*212*55 Weight:kg 1.4 NO. NO.59-2</p>
Remarks: SHACMAN 10JSD140		Remarks: SHACMAN 11509C 9JS135 12JS160T 12JS160TA 12JS200T	

SHACMAN(1)

	<p>Part No. 12JS160T-1707060</p> <p>CH part name 换挡气缸双</p> <p>EN part name Shift cylinder assy.</p> <p>RU part name Цилиндр переключения высш/низш</p> <p>Size:mm 240*145*140</p> <p>Weight:kg 6.49</p> <p>NO. NO.59-7</p>		<p>Part No. RTD-11609A-1707067</p> <p>CH part name 副箱拨叉</p> <p>EN part name Sub-gearbox shift fork</p> <p>RU part name Вилка делителя передач</p> <p>Size:mm 222*187*47</p> <p>Weight:kg 1.35</p> <p>NO. NO.59-2</p>
Remarks: SHACMAN F3000 F2000 12JS200T A-C09016		Remarks: SHACMAN 10JSD140 10JSD160 10JSD180	
	<p>Part No. 192311E</p> <p>CH part name 焊接轴后轴承</p> <p>EN part name Bearing</p> <p>RU part name Подшипник</p> <p>Size:mm 120*29</p> <p>Weight:kg 0.73</p> <p>NO. NO.59-12</p>		<p>Part No. 42308E</p> <p>CH part name 焊接轴前轴承</p> <p>EN part name Bearing</p> <p>RU part name Подшипник</p> <p>Size:mm 120*29</p> <p>Weight:kg 0.73</p> <p>NO. NO.59-12</p>
Remarks: SHACMAN F3000 F2000		Remarks: SHACMAN F3000 F2000	
	<p>Part No. JS180-1707155</p> <p>CH part name 输出轴后轴承盖</p> <p>EN part name Rear bearing cover</p> <p>RU part name Понижающая шестерня главного вала</p> <p>Size:mm 160*104*56</p> <p>Weight:kg 2.59</p> <p>NO. NO.59-21</p>		<p>Part No. F96006</p> <p>CH part name 凸缘螺母</p> <p>EN part name Flanged nut</p> <p>RU part name многолопастная ореха</p> <p>Size:mm</p> <p>Weight:kg 0.45</p> <p>NO. NO.59-16</p>
Remarks: SHACMAN F3000 F2000 F99967		Remarks: SHACMAN F3000 F2000	
	<p>Part No. 12JS160T-1707105</p> <p>CH part name 副箱主轴</p> <p>EN part name Main shaft</p> <p>RU part name Главный вал делителя передач</p> <p>Size:mm</p> <p>Weight:kg 6.5</p> <p>NO. NO.59-9</p>		<p>Part No. 12JSD160T-1707105</p> <p>CH part name 副箱主轴</p> <p>EN part name Main shaft</p> <p>RU part name Главный вал делителя передач</p> <p>Size:mm</p> <p>Weight:kg 6.5</p> <p>NO. NO.59-9</p>
Remarks: SHACMAN 12JS160T 12JS160TA 12JS200T		Remarks: SHACMAN 10JSD160 10JSD180	

SHACMAN(1)

	<table border="1"> <tr><td>Part No.</td><td>F99882</td></tr> <tr><td>CH part name</td><td>副箱主轴</td></tr> <tr><td>EN part name</td><td>Main shaft</td></tr> <tr><td>RU part name</td><td>Главный вал делителя передач</td></tr> <tr><td>Size:mm</td><td>280*75</td></tr> <tr><td>Weight:kg</td><td>6.89</td></tr> <tr><td>NO.</td><td>NO.59-9</td></tr> </table>	Part No.	F99882	CH part name	副箱主轴	EN part name	Main shaft	RU part name	Главный вал делителя передач	Size:mm	280*75	Weight:kg	6.89	NO.	NO.59-9		<table border="1"> <tr><td>Part No.</td><td>RTD-11609A-1707105</td></tr> <tr><td>CH part name</td><td>副箱主轴</td></tr> <tr><td>EN part name</td><td>Main shaft</td></tr> <tr><td>RU part name</td><td>Главный вал делителя передач</td></tr> <tr><td>Size:mm</td><td></td></tr> <tr><td>Weight:kg</td><td>4</td></tr> <tr><td>NO.</td><td>NO.59-9</td></tr> </table>	Part No.	RTD-11609A-1707105	CH part name	副箱主轴	EN part name	Main shaft	RU part name	Главный вал делителя передач	Size:mm		Weight:kg	4	NO.	NO.59-9
Part No.	F99882																														
CH part name	副箱主轴																														
EN part name	Main shaft																														
RU part name	Главный вал делителя передач																														
Size:mm	280*75																														
Weight:kg	6.89																														
NO.	NO.59-9																														
Part No.	RTD-11609A-1707105																														
CH part name	副箱主轴																														
EN part name	Main shaft																														
RU part name	Главный вал делителя передач																														
Size:mm																															
Weight:kg	4																														
NO.	NO.59-9																														
Remarks: SHACMAN 11509C 9JS135		Remarks: SHACMAN 10JSD140																													
	<table border="1"> <tr><td>Part No.</td><td>10JSD140-1707106</td></tr> <tr><td>CH part name</td><td>减速齿轮</td></tr> <tr><td>EN part name</td><td>Reduction gear,aux.mainshaft</td></tr> <tr><td>RU part name</td><td>редуктор, aux.mainshaft</td></tr> <tr><td>Size:mm</td><td></td></tr> <tr><td>Weight:kg</td><td>4.55</td></tr> <tr><td>NO.</td><td>NO.59-10</td></tr> </table>	Part No.	10JSD140-1707106	CH part name	减速齿轮	EN part name	Reduction gear,aux.mainshaft	RU part name	редуктор, aux.mainshaft	Size:mm		Weight:kg	4.55	NO.	NO.59-10		<table border="1"> <tr><td>Part No.</td><td>12JS160T-1707106</td></tr> <tr><td>CH part name</td><td>副箱主轴减速齿轮</td></tr> <tr><td>EN part name</td><td>Reduction gear,aux.mainshaft</td></tr> <tr><td>RU part name</td><td>редуктор, aux.mainshaft</td></tr> <tr><td>Size:mm</td><td>225*102*38</td></tr> <tr><td>Weight:kg</td><td>5.01</td></tr> <tr><td>NO.</td><td>NO.59-10</td></tr> </table>	Part No.	12JS160T-1707106	CH part name	副箱主轴减速齿轮	EN part name	Reduction gear,aux.mainshaft	RU part name	редуктор, aux.mainshaft	Size:mm	225*102*38	Weight:kg	5.01	NO.	NO.59-10
Part No.	10JSD140-1707106																														
CH part name	减速齿轮																														
EN part name	Reduction gear,aux.mainshaft																														
RU part name	редуктор, aux.mainshaft																														
Size:mm																															
Weight:kg	4.55																														
NO.	NO.59-10																														
Part No.	12JS160T-1707106																														
CH part name	副箱主轴减速齿轮																														
EN part name	Reduction gear,aux.mainshaft																														
RU part name	редуктор, aux.mainshaft																														
Size:mm	225*102*38																														
Weight:kg	5.01																														
NO.	NO.59-10																														
Remarks: SHACMAN 10JSD140		Remarks: SHACMAN 12JS160T 12JS160TA																													
	<table border="1"> <tr><td>Part No.</td><td>19726</td></tr> <tr><td>CH part name</td><td>减速齿轮</td></tr> <tr><td>EN part name</td><td>Reduction gear,aux.mainshaft</td></tr> <tr><td>RU part name</td><td>редуктор, aux.mainshaft</td></tr> <tr><td>Size:mm</td><td>225*102*38</td></tr> <tr><td>Weight:kg</td><td>5.01</td></tr> <tr><td>NO.</td><td>NO.59-10</td></tr> </table>	Part No.	19726	CH part name	减速齿轮	EN part name	Reduction gear,aux.mainshaft	RU part name	редуктор, aux.mainshaft	Size:mm	225*102*38	Weight:kg	5.01	NO.	NO.59-10		<table border="1"> <tr><td>Part No.</td><td>12JSD160T-1707106</td></tr> <tr><td>CH part name</td><td>减速齿轮</td></tr> <tr><td>EN part name</td><td>Reduction gear,aux.mainshaft</td></tr> <tr><td>RU part name</td><td>редуктор, aux.mainshaft</td></tr> <tr><td>Size:mm</td><td></td></tr> <tr><td>Weight:kg</td><td>8.6</td></tr> <tr><td>NO.</td><td>NO.59-10</td></tr> </table>	Part No.	12JSD160T-1707106	CH part name	减速齿轮	EN part name	Reduction gear,aux.mainshaft	RU part name	редуктор, aux.mainshaft	Size:mm		Weight:kg	8.6	NO.	NO.59-10
Part No.	19726																														
CH part name	减速齿轮																														
EN part name	Reduction gear,aux.mainshaft																														
RU part name	редуктор, aux.mainshaft																														
Size:mm	225*102*38																														
Weight:kg	5.01																														
NO.	NO.59-10																														
Part No.	12JSD160T-1707106																														
CH part name	减速齿轮																														
EN part name	Reduction gear,aux.mainshaft																														
RU part name	редуктор, aux.mainshaft																														
Size:mm																															
Weight:kg	8.6																														
NO.	NO.59-10																														
Remarks: SHACMAN 11509C 9JS135		Remarks: SHACMAN 10JSD160 10JSD180																													
	<table border="1"> <tr><td>Part No.</td><td>12JS200T-1707106</td></tr> <tr><td>CH part name</td><td>减速齿轮</td></tr> <tr><td>EN part name</td><td>Reduction gear,aux.mainshaft</td></tr> <tr><td>RU part name</td><td>редуктор, aux.mainshaft</td></tr> <tr><td>Size:mm</td><td>236*58</td></tr> <tr><td>Weight:kg</td><td>8.6</td></tr> <tr><td>NO.</td><td>NO.59-10</td></tr> </table>	Part No.	12JS200T-1707106	CH part name	减速齿轮	EN part name	Reduction gear,aux.mainshaft	RU part name	редуктор, aux.mainshaft	Size:mm	236*58	Weight:kg	8.6	NO.	NO.59-10		<table border="1"> <tr><td>Part No.</td><td>16763</td></tr> <tr><td>CH part name</td><td>止动环</td></tr> <tr><td>EN part name</td><td>Stop ring</td></tr> <tr><td>RU part name</td><td>Упорный кольцо</td></tr> <tr><td>Size:mm</td><td></td></tr> <tr><td>Weight:kg</td><td>0.02</td></tr> <tr><td>NO.</td><td>NO.59a-1</td></tr> </table>	Part No.	16763	CH part name	止动环	EN part name	Stop ring	RU part name	Упорный кольцо	Size:mm		Weight:kg	0.02	NO.	NO.59a-1
Part No.	12JS200T-1707106																														
CH part name	减速齿轮																														
EN part name	Reduction gear,aux.mainshaft																														
RU part name	редуктор, aux.mainshaft																														
Size:mm	236*58																														
Weight:kg	8.6																														
NO.	NO.59-10																														
Part No.	16763																														
CH part name	止动环																														
EN part name	Stop ring																														
RU part name	Упорный кольцо																														
Size:mm																															
Weight:kg	0.02																														
NO.	NO.59a-1																														
Remarks: SHACMAN 12JS200T		Remarks: SHACMAN 11509C 9JS135 12JS160T 12JS160TA																													







SHACMAN(1)

AUX GEAR BOX ASSEMBLY		NO.59a																													
		KD0806-5																													
			<table border="1"> <tr><td>Part No.</td><td>16628</td></tr> <tr><td>CH part name</td><td>止动环</td></tr> <tr><td>EN part name</td><td>Stop ring</td></tr> <tr><td>RU part name</td><td>Упорный кольцо</td></tr> <tr><td>Size:mm</td><td></td></tr> <tr><td>Weight:kg</td><td>0.032</td></tr> <tr><td>NO.</td><td>NO.59a-3</td></tr> </table>	Part No.	16628	CH part name	止动环	EN part name	Stop ring	RU part name	Упорный кольцо	Size:mm		Weight:kg	0.032	NO.	NO.59a-3														
		Part No.	16628																												
		CH part name	止动环																												
		EN part name	Stop ring																												
		RU part name	Упорный кольцо																												
Size:mm																															
Weight:kg	0.032																														
NO.	NO.59a-3																														
Remarks: SHACMAN 11509C 9JS135																															
KD0806-6																															
	<table border="1"> <tr><td>Part No.</td><td>16138</td></tr> <tr><td>CH part name</td><td>副箱轴承定位盘</td></tr> <tr><td>EN part name</td><td>Sub-gearbox bearing locating disc</td></tr> <tr><td>RU part name</td><td>Установочный диск</td></tr> <tr><td>Size:mm</td><td></td></tr> <tr><td>Weight:kg</td><td>0.21</td></tr> <tr><td>NO.</td><td>NO.59a-6</td></tr> </table>	Part No.	16138	CH part name	副箱轴承定位盘	EN part name	Sub-gearbox bearing locating disc	RU part name	Установочный диск	Size:mm		Weight:kg	0.21	NO.	NO.59a-6																
Part No.	16138																														
CH part name	副箱轴承定位盘																														
EN part name	Sub-gearbox bearing locating disc																														
RU part name	Установочный диск																														
Size:mm																															
Weight:kg	0.21																														
NO.	NO.59a-6																														
Remarks: SHACMAN 11509C 9JS135																															
KD0805-5		KD0806-7																													
	<table border="1"> <tr><td>Part No.</td><td>50118</td></tr> <tr><td>CH part name</td><td>带止动槽的单列向心球轴承</td></tr> <tr><td>EN part name</td><td>Single-row radial ball bearing.</td></tr> <tr><td>RU part name</td><td>Статус в сердце шарикоподшипник</td></tr> <tr><td>Size:mm</td><td>90*140*24</td></tr> <tr><td>Weight:kg</td><td>0.75</td></tr> <tr><td>NO.</td><td>NO.59a-4</td></tr> </table>	Part No.	50118	CH part name	带止动槽的单列向心球轴承	EN part name	Single-row radial ball bearing.	RU part name	Статус в сердце шарикоподшипник	Size:mm	90*140*24	Weight:kg	0.75	NO.	NO.59a-4		<table border="1"> <tr><td>Part No.</td><td>C01019</td></tr> <tr><td>CH part name</td><td>止动环</td></tr> <tr><td>EN part name</td><td>Stop ring</td></tr> <tr><td>RU part name</td><td>Упорный кольцо</td></tr> <tr><td>Size:mm</td><td></td></tr> <tr><td>Weight:kg</td><td>0.05</td></tr> <tr><td>NO.</td><td>NO.59a-5</td></tr> </table>	Part No.	C01019	CH part name	止动环	EN part name	Stop ring	RU part name	Упорный кольцо	Size:mm		Weight:kg	0.05	NO.	NO.59a-5
Part No.	50118																														
CH part name	带止动槽的单列向心球轴承																														
EN part name	Single-row radial ball bearing.																														
RU part name	Статус в сердце шарикоподшипник																														
Size:mm	90*140*24																														
Weight:kg	0.75																														
NO.	NO.59a-4																														
Part No.	C01019																														
CH part name	止动环																														
EN part name	Stop ring																														
RU part name	Упорный кольцо																														
Size:mm																															
Weight:kg	0.05																														
NO.	NO.59a-5																														
Remarks: SHACMAN 11509C 9JS135		Remarks: SHACMAN 11509C 9JS135																													
KD0805-6		KD0806-8																													
	<table border="1"> <tr><td>Part No.</td><td>12JS160T-1707030</td></tr> <tr><td>CH part name</td><td>副箱驱动齿轮</td></tr> <tr><td>EN part name</td><td>Sub-gearbox drive gear</td></tr> <tr><td>RU part name</td><td>Заместитель коробка передач привода</td></tr> <tr><td>Size:mm</td><td>140*58</td></tr> <tr><td>Weight:kg</td><td>3.205</td></tr> <tr><td>NO.</td><td>NO.59a-9</td></tr> </table>	Part No.	12JS160T-1707030	CH part name	副箱驱动齿轮	EN part name	Sub-gearbox drive gear	RU part name	Заместитель коробка передач привода	Size:mm	140*58	Weight:kg	3.205	NO.	NO.59a-9		<table border="1"> <tr><td>Part No.</td><td>18869</td></tr> <tr><td>CH part name</td><td>副箱驱动齿轮</td></tr> <tr><td>EN part name</td><td>Sub-gearbox drive gear</td></tr> <tr><td>RU part name</td><td>Заместитель коробка передач привода</td></tr> <tr><td>Size:mm</td><td></td></tr> <tr><td>Weight:kg</td><td>2.55</td></tr> <tr><td>NO.</td><td>NO.59a-9</td></tr> </table>	Part No.	18869	CH part name	副箱驱动齿轮	EN part name	Sub-gearbox drive gear	RU part name	Заместитель коробка передач привода	Size:mm		Weight:kg	2.55	NO.	NO.59a-9
Part No.	12JS160T-1707030																														
CH part name	副箱驱动齿轮																														
EN part name	Sub-gearbox drive gear																														
RU part name	Заместитель коробка передач привода																														
Size:mm	140*58																														
Weight:kg	3.205																														
NO.	NO.59a-9																														
Part No.	18869																														
CH part name	副箱驱动齿轮																														
EN part name	Sub-gearbox drive gear																														
RU part name	Заместитель коробка передач привода																														
Size:mm																															
Weight:kg	2.55																														
NO.	NO.59a-9																														
Remarks: SHACMAN 12JS160T 12JS160TA		Remarks: SHACMAN 11509C 9JS135																													

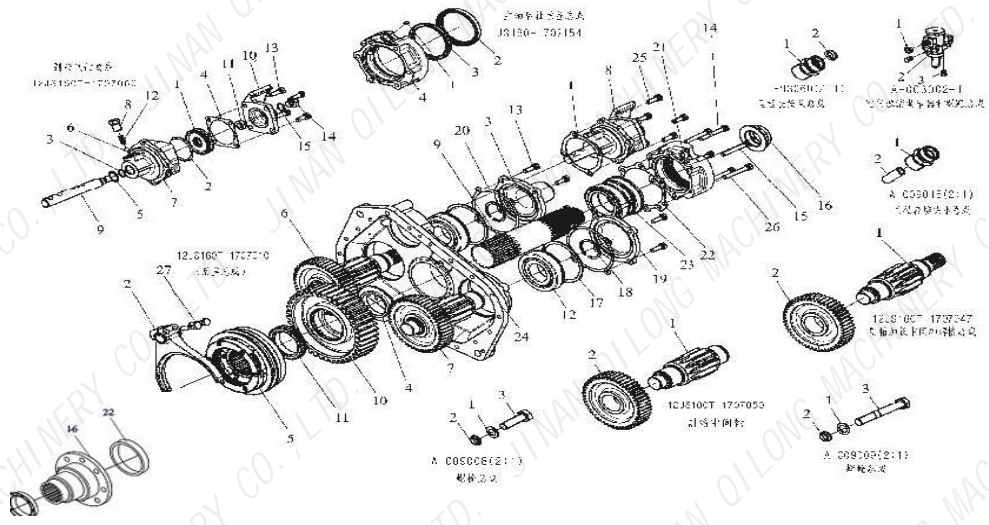
SHACMAN(1)

	<table border="1"> <tr><td>Part No.</td><td>12JS200T-1707030</td></tr> <tr><td>CH part name</td><td>副箱驱动齿轮</td></tr> <tr><td>EN part name</td><td>Sub-gearbox drive gear</td></tr> <tr><td>RU part name</td><td>Заместитель коробка передач привода</td></tr> <tr><td>Size:mm</td><td>138*58</td></tr> <tr><td>Weight:kg</td><td>3.48</td></tr> <tr><td>NO.</td><td>NO.59a-9</td></tr> </table>	Part No.	12JS200T-1707030	CH part name	副箱驱动齿轮	EN part name	Sub-gearbox drive gear	RU part name	Заместитель коробка передач привода	Size:mm	138*58	Weight:kg	3.48	NO.	NO.59a-9		<table border="1"> <tr><td>Part No.</td><td>10JSD160-1707030</td></tr> <tr><td>CH part name</td><td>副箱驱动齿轮</td></tr> <tr><td>EN part name</td><td>Sub-gearbox drive gear</td></tr> <tr><td>RU part name</td><td>Заместитель коробка передач привода</td></tr> <tr><td>Size:mm</td><td>146*92</td></tr> <tr><td>Weight:kg</td><td>4.2</td></tr> <tr><td>NO.</td><td>NO.59a-9</td></tr> </table>	Part No.	10JSD160-1707030	CH part name	副箱驱动齿轮	EN part name	Sub-gearbox drive gear	RU part name	Заместитель коробка передач привода	Size:mm	146*92	Weight:kg	4.2	NO.	NO.59a-9
Part No.	12JS200T-1707030																														
CH part name	副箱驱动齿轮																														
EN part name	Sub-gearbox drive gear																														
RU part name	Заместитель коробка передач привода																														
Size:mm	138*58																														
Weight:kg	3.48																														
NO.	NO.59a-9																														
Part No.	10JSD160-1707030																														
CH part name	副箱驱动齿轮																														
EN part name	Sub-gearbox drive gear																														
RU part name	Заместитель коробка передач привода																														
Size:mm	146*92																														
Weight:kg	4.2																														
NO.	NO.59a-9																														
Remarks: SHACMAN 12JS200T		Remarks: SHACMAN 10JSD160 10JSD180																													
	<table border="1"> <tr><td>Part No.</td><td>10JSD140-1707030</td></tr> <tr><td>CH part name</td><td>副箱驱动齿轮</td></tr> <tr><td>EN part name</td><td>Sub-gearbox drive gear</td></tr> <tr><td>RU part name</td><td>Заместитель коробка передач привода</td></tr> <tr><td>Size:mm</td><td>145*86</td></tr> <tr><td>Weight:kg</td><td>3.755</td></tr> <tr><td>NO.</td><td>NO.59a-9</td></tr> </table>	Part No.	10JSD140-1707030	CH part name	副箱驱动齿轮	EN part name	Sub-gearbox drive gear	RU part name	Заместитель коробка передач привода	Size:mm	145*86	Weight:kg	3.755	NO.	NO.59a-9		<table border="1"> <tr><td>Part No.</td><td>A-C09005</td></tr> <tr><td>CH part name</td><td>高低档同步器 (副箱)</td></tr> <tr><td>EN part name</td><td>Synchronizer assy.</td></tr> <tr><td>RU part name</td><td>Синхронизатор</td></tr> <tr><td>Size:mm</td><td>300*300*100</td></tr> <tr><td>Weight:kg</td><td>5.2</td></tr> <tr><td>NO.</td><td>NO.59-5</td></tr> </table>	Part No.	A-C09005	CH part name	高低档同步器 (副箱)	EN part name	Synchronizer assy.	RU part name	Синхронизатор	Size:mm	300*300*100	Weight:kg	5.2	NO.	NO.59-5
Part No.	10JSD140-1707030																														
CH part name	副箱驱动齿轮																														
EN part name	Sub-gearbox drive gear																														
RU part name	Заместитель коробка передач привода																														
Size:mm	145*86																														
Weight:kg	3.755																														
NO.	NO.59a-9																														
Part No.	A-C09005																														
CH part name	高低档同步器 (副箱)																														
EN part name	Synchronizer assy.																														
RU part name	Синхронизатор																														
Size:mm	300*300*100																														
Weight:kg	5.2																														
NO.	NO.59-5																														
Remarks: SHACMAN 10JSD140		Remarks: SHACMAN 11509C 9JS135																													
	<table border="1"> <tr><td>Part No.</td><td>12JS160T-1707140-1</td></tr> <tr><td>CH part name</td><td>副箱同步器</td></tr> <tr><td>EN part name</td><td>Synchronizer assy.</td></tr> <tr><td>RU part name</td><td>Синхронизатор</td></tr> <tr><td>Size:mm</td><td>200*75</td></tr> <tr><td>Weight:kg</td><td>5.85</td></tr> <tr><td>NO.</td><td>NO.59-5</td></tr> </table>	Part No.	12JS160T-1707140-1	CH part name	副箱同步器	EN part name	Synchronizer assy.	RU part name	Синхронизатор	Size:mm	200*75	Weight:kg	5.85	NO.	NO.59-5		<table border="1"> <tr><td>Part No.</td><td>RTD-11609A-1707140</td></tr> <tr><td>CH part name</td><td>副箱同步器</td></tr> <tr><td>EN part name</td><td>Synchronizer assy.</td></tr> <tr><td>RU part name</td><td>Синхронизатор</td></tr> <tr><td>Size:mm</td><td></td></tr> <tr><td>Weight:kg</td><td>5.15</td></tr> <tr><td>NO.</td><td>NO.59-5</td></tr> </table>	Part No.	RTD-11609A-1707140	CH part name	副箱同步器	EN part name	Synchronizer assy.	RU part name	Синхронизатор	Size:mm		Weight:kg	5.15	NO.	NO.59-5
Part No.	12JS160T-1707140-1																														
CH part name	副箱同步器																														
EN part name	Synchronizer assy.																														
RU part name	Синхронизатор																														
Size:mm	200*75																														
Weight:kg	5.85																														
NO.	NO.59-5																														
Part No.	RTD-11609A-1707140																														
CH part name	副箱同步器																														
EN part name	Synchronizer assy.																														
RU part name	Синхронизатор																														
Size:mm																															
Weight:kg	5.15																														
NO.	NO.59-5																														
Remarks: SHACMAN 12JS160T 12JS160TA 12JS200T		Remarks: SHACMAN 10JSD140																													
	<table border="1"> <tr><td>Part No.</td><td>12JSD160T-1707140</td></tr> <tr><td>CH part name</td><td>副箱同步器</td></tr> <tr><td>EN part name</td><td>Synchronizer assy.</td></tr> <tr><td>RU part name</td><td>Синхронизатор</td></tr> <tr><td>Size:mm</td><td></td></tr> <tr><td>Weight:kg</td><td>5.25</td></tr> <tr><td>NO.</td><td>NO.59-5</td></tr> </table>	Part No.	12JSD160T-1707140	CH part name	副箱同步器	EN part name	Synchronizer assy.	RU part name	Синхронизатор	Size:mm		Weight:kg	5.25	NO.	NO.59-5		<table border="1"> <tr><td>Part No.</td><td>16JSS300T-1707109</td></tr> <tr><td>CH part name</td><td>组合轴承</td></tr> <tr><td>EN part name</td><td>Bearing</td></tr> <tr><td>RU part name</td><td>Подшипники</td></tr> <tr><td>Size:mm</td><td></td></tr> <tr><td>Weight:kg</td><td>2.9</td></tr> <tr><td>NO.</td><td>NO.59-23</td></tr> </table>	Part No.	16JSS300T-1707109	CH part name	组合轴承	EN part name	Bearing	RU part name	Подшипники	Size:mm		Weight:kg	2.9	NO.	NO.59-23
Part No.	12JSD160T-1707140																														
CH part name	副箱同步器																														
EN part name	Synchronizer assy.																														
RU part name	Синхронизатор																														
Size:mm																															
Weight:kg	5.25																														
NO.	NO.59-5																														
Part No.	16JSS300T-1707109																														
CH part name	组合轴承																														
EN part name	Bearing																														
RU part name	Подшипники																														
Size:mm																															
Weight:kg	2.9																														
NO.	NO.59-23																														
Remarks: SHACMAN 10JSD160 10JSD180		Remarks: SHACMAN																													

SHACMAN(1)

AUX GEAR BOX ASSEMBLY		NO.59															
	KD0806-13																
			<table border="1"> <tr><td>Part No.</td><td>JS200-1707109</td></tr> <tr><td>CH part name</td><td>组合轴承</td></tr> <tr><td>EN part name</td><td>Bearing</td></tr> <tr><td>RU part name</td><td>Подшипники</td></tr> <tr><td>Size:mm</td><td>102*132*87</td></tr> <tr><td>Weight:kg</td><td>2.45</td></tr> <tr><td>NO.</td><td>NO.59-23</td></tr> </table>	Part No.	JS200-1707109	CH part name	组合轴承	EN part name	Bearing	RU part name	Подшипники	Size:mm	102*132*87	Weight:kg	2.45	NO.	NO.59-23
	Part No.	JS200-1707109															
	CH part name	组合轴承															
	EN part name	Bearing															
	RU part name	Подшипники															
	Size:mm	102*132*87															
	Weight:kg	2.45															
	NO.	NO.59-23															
	Remarks: SHACMAN 717813 JS220 JS180																
KD0806-14																	
		<table border="1"> <tr><td>Part No.</td><td>RTD-11609A-1707109</td></tr> <tr><td>CH part name</td><td>组合轴承</td></tr> <tr><td>EN part name</td><td>Bearing</td></tr> <tr><td>RU part name</td><td>Подшипники</td></tr> <tr><td>Size:mm</td><td></td></tr> <tr><td>Weight:kg</td><td></td></tr> <tr><td>NO.</td><td>NO.59-23</td></tr> </table>	Part No.	RTD-11609A-1707109	CH part name	组合轴承	EN part name	Bearing	RU part name	Подшипники	Size:mm		Weight:kg		NO.	NO.59-23	
Part No.	RTD-11609A-1707109																
CH part name	组合轴承																
EN part name	Bearing																
RU part name	Подшипники																
Size:mm																	
Weight:kg																	
NO.	NO.59-23																
Remarks: SHACMAN 10JSD140																	
KD0805-11																	
	Part No.	19109/C01032															
	CH part name	变速箱后油封															
	EN part name	Gearbox front oil seal															
	RU part name	Сальник передний КПП															
	Size:mm	114*95*12/8															
	Weight:kg	0.125															
	NO.	NO.59-2															
Remarks: SHACMAN																	
KD0805-12																	
	Part No.	12JS160T-1707047															
	CH part name	焊接轴(花)															
	EN part name	Welding shaft (flower)															
	RU part name	Сварка вал (цветы)															
	Size:mm																
	Weight:kg	9.8															
	NO.	NO.59-6															
Remarks: SHACMAN 12JS160T 12JS160TA																	
KD0806-15																	
	Part No.	12JS160T-1707050															
	CH part name	焊接轴(光)															
	EN part name	Welding shaft (light)															
	RU part name	Сварка вал (света)															
	Size:mm	150*256															
	Weight:kg	7.8															
	NO.	NO.59-9															
Remarks: SHACMAN 12JS160T 12JS160TA																	
KD0806-16																	
	Part No.	12JS200T-1707050															
	CH part name	焊接轴(光)															
	EN part name	Welding shaft (light)															
	RU part name	Сварка вал (света)															
	Size:mm	202*182															
	Weight:kg	9.215															
	NO.	NO.59-9															
Remarks: SHACMAN 12JS200T																	

SHACMAN(1)

	<p>KD0805-13</p> <table border="1"> <tr><td>Part No.</td><td>12JS200T-1707047</td></tr> <tr><td>CH part name</td><td>焊接轴 (花)</td></tr> <tr><td>EN part name</td><td>Welding shaft (flower)</td></tr> <tr><td>RU part name</td><td>Сварка вал (цветы)</td></tr> <tr><td>Size:mm</td><td>274*182</td></tr> <tr><td>Weight:kg</td><td>9.8</td></tr> <tr><td>NO.</td><td>NO.59-6</td></tr> </table>	Part No.	12JS200T-1707047	CH part name	焊接轴 (花)	EN part name	Welding shaft (flower)	RU part name	Сварка вал (цветы)	Size:mm	274*182	Weight:kg	9.8	NO.	NO.59-6		<p>KD0806-17</p> <table border="1"> <tr><td>Part No.</td><td>18222</td></tr> <tr><td>CH part name</td><td>焊接轴</td></tr> <tr><td>EN part name</td><td>Welding shaft</td></tr> <tr><td>RU part name</td><td>Сварка вал</td></tr> <tr><td>Size:mm</td><td></td></tr> <tr><td>Weight:kg</td><td>6.8</td></tr> <tr><td>NO.</td><td>NO.59-6</td></tr> </table>	Part No.	18222	CH part name	焊接轴	EN part name	Welding shaft	RU part name	Сварка вал	Size:mm		Weight:kg	6.8	NO.	NO.59-6
Part No.	12JS200T-1707047																														
CH part name	焊接轴 (花)																														
EN part name	Welding shaft (flower)																														
RU part name	Сварка вал (цветы)																														
Size:mm	274*182																														
Weight:kg	9.8																														
NO.	NO.59-6																														
Part No.	18222																														
CH part name	焊接轴																														
EN part name	Welding shaft																														
RU part name	Сварка вал																														
Size:mm																															
Weight:kg	6.8																														
NO.	NO.59-6																														
Remarks: SHACMAN 12JS200T		Remarks: SHACMAN 11509C 9JS135 RTD-11509C-1707047																													
	<p>KD1065</p> <table border="1"> <tr><td>Part No.</td><td>10JSD140-1707047</td></tr> <tr><td>CH part name</td><td>焊接轴 (花)</td></tr> <tr><td>EN part name</td><td>Welding shaft (flower)</td></tr> <tr><td>RU part name</td><td>Сварка вал (цветы)</td></tr> <tr><td>Size:mm</td><td>262*182</td></tr> <tr><td>Weight:kg</td><td>7.76</td></tr> <tr><td>NO.</td><td>NO.59-6</td></tr> </table>	Part No.	10JSD140-1707047	CH part name	焊接轴 (花)	EN part name	Welding shaft (flower)	RU part name	Сварка вал (цветы)	Size:mm	262*182	Weight:kg	7.76	NO.	NO.59-6		<p>KD1066</p> <table border="1"> <tr><td>Part No.</td><td>JS130T-1707047</td></tr> <tr><td>CH part name</td><td>焊接轴</td></tr> <tr><td>EN part name</td><td>Sub-gearbox welded intermedi</td></tr> <tr><td>RU part name</td><td>Промежуточный вал делителя</td></tr> <tr><td>Size:mm</td><td>280*158*158</td></tr> <tr><td>Weight:kg</td><td>7.5</td></tr> <tr><td>NO.</td><td>NO.59-6</td></tr> </table>	Part No.	JS130T-1707047	CH part name	焊接轴	EN part name	Sub-gearbox welded intermedi	RU part name	Промежуточный вал делителя	Size:mm	280*158*158	Weight:kg	7.5	NO.	NO.59-6
Part No.	10JSD140-1707047																														
CH part name	焊接轴 (花)																														
EN part name	Welding shaft (flower)																														
RU part name	Сварка вал (цветы)																														
Size:mm	262*182																														
Weight:kg	7.76																														
NO.	NO.59-6																														
Part No.	JS130T-1707047																														
CH part name	焊接轴																														
EN part name	Sub-gearbox welded intermedi																														
RU part name	Промежуточный вал делителя																														
Size:mm	280*158*158																														
Weight:kg	7.5																														
NO.	NO.59-6																														
Remarks: SHACMAN 10JSD140		Remarks: SHACMAN																													
	<p>KD1067</p> <table border="1"> <tr><td>Part No.</td><td>10JSD140-1707050</td></tr> <tr><td>CH part name</td><td>焊接轴 (光)</td></tr> <tr><td>EN part name</td><td>Welding shaft (light)</td></tr> <tr><td>RU part name</td><td>Сварка вал (света)</td></tr> <tr><td>Size:mm</td><td>182*182</td></tr> <tr><td>Weight:kg</td><td>7.095</td></tr> <tr><td>NO.</td><td>NO.59-9</td></tr> </table>	Part No.	10JSD140-1707050	CH part name	焊接轴 (光)	EN part name	Welding shaft (light)	RU part name	Сварка вал (света)	Size:mm	182*182	Weight:kg	7.095	NO.	NO.59-9		<p>KD1068</p> <table border="1"> <tr><td>Part No.</td><td>12JSD160T-1707047</td></tr> <tr><td>CH part name</td><td>焊接轴 (花)</td></tr> <tr><td>EN part name</td><td>Welding shaft (flower)</td></tr> <tr><td>RU part name</td><td>Сварка вал (цветы)</td></tr> <tr><td>Size:mm</td><td></td></tr> <tr><td>Weight:kg</td><td>9.1</td></tr> <tr><td>NO.</td><td>NO.59-6</td></tr> </table>	Part No.	12JSD160T-1707047	CH part name	焊接轴 (花)	EN part name	Welding shaft (flower)	RU part name	Сварка вал (цветы)	Size:mm		Weight:kg	9.1	NO.	NO.59-6
Part No.	10JSD140-1707050																														
CH part name	焊接轴 (光)																														
EN part name	Welding shaft (light)																														
RU part name	Сварка вал (света)																														
Size:mm	182*182																														
Weight:kg	7.095																														
NO.	NO.59-9																														
Part No.	12JSD160T-1707047																														
CH part name	焊接轴 (花)																														
EN part name	Welding shaft (flower)																														
RU part name	Сварка вал (цветы)																														
Size:mm																															
Weight:kg	9.1																														
NO.	NO.59-6																														
Remarks: SHACMAN 10JSD140		Remarks: SHACMAN 10JSD160 10JSD180																													
	<p>KD1069</p> <table border="1"> <tr><td>Part No.</td><td>11509C-1707047</td></tr> <tr><td>CH part name</td><td>焊接轴(花)</td></tr> <tr><td>EN part name</td><td>Welding shaft (flower)</td></tr> <tr><td>RU part name</td><td>Сварка вал (цветы)</td></tr> <tr><td>Size:mm</td><td>256*172</td></tr> <tr><td>Weight:kg</td><td>7.82</td></tr> <tr><td>NO.</td><td>NO.59-6</td></tr> </table>	Part No.	11509C-1707047	CH part name	焊接轴(花)	EN part name	Welding shaft (flower)	RU part name	Сварка вал (цветы)	Size:mm	256*172	Weight:kg	7.82	NO.	NO.59-6		<p>KD1070</p> <table border="1"> <tr><td>Part No.</td><td>12JSD160T-1707050</td></tr> <tr><td>CH part name</td><td>焊接轴 (光)</td></tr> <tr><td>EN part name</td><td>Welding shaft (light)</td></tr> <tr><td>RU part name</td><td>Сварка вал (света)</td></tr> <tr><td>Size:mm</td><td></td></tr> <tr><td>Weight:kg</td><td>8.5</td></tr> <tr><td>NO.</td><td>NO.59-9</td></tr> </table>	Part No.	12JSD160T-1707050	CH part name	焊接轴 (光)	EN part name	Welding shaft (light)	RU part name	Сварка вал (света)	Size:mm		Weight:kg	8.5	NO.	NO.59-9
Part No.	11509C-1707047																														
CH part name	焊接轴(花)																														
EN part name	Welding shaft (flower)																														
RU part name	Сварка вал (цветы)																														
Size:mm	256*172																														
Weight:kg	7.82																														
NO.	NO.59-6																														
Part No.	12JSD160T-1707050																														
CH part name	焊接轴 (光)																														
EN part name	Welding shaft (light)																														
RU part name	Сварка вал (света)																														
Size:mm																															
Weight:kg	8.5																														
NO.	NO.59-9																														
Remarks: SHACMAN 11509C		Remarks: SHACMAN 10JSD160 10JSD180																													

SHACMAN(1)

	<table border="1"> <tr><td>Part No.</td><td>11509C-1707050</td></tr> <tr><td>CH part name</td><td>焊接轴 (光)</td></tr> <tr><td>EN part name</td><td>Welding shaft (light)</td></tr> <tr><td>RU part name</td><td>Сварка вал (света)</td></tr> <tr><td>Size:mm</td><td></td></tr> <tr><td>Weight:kg</td><td>6.98</td></tr> <tr><td>NO.</td><td>NO.59-9</td></tr> </table>	Part No.	11509C-1707050	CH part name	焊接轴 (光)	EN part name	Welding shaft (light)	RU part name	Сварка вал (света)	Size:mm		Weight:kg	6.98	NO.	NO.59-9		<table border="1"> <tr><td>Part No.</td><td>JS180-1707052</td></tr> <tr><td>CH part name</td><td>副箱中间轴盖</td></tr> <tr><td>EN part name</td><td>Intermediate shaft cover</td></tr> <tr><td>RU part name</td><td>Промежуточный крышка</td></tr> <tr><td>Size:mm</td><td>143*20</td></tr> <tr><td>Weight:kg</td><td>0.33</td></tr> <tr><td>NO.</td><td>NO.59-19</td></tr> </table>	Part No.	JS180-1707052	CH part name	副箱中间轴盖	EN part name	Intermediate shaft cover	RU part name	Промежуточный крышка	Size:mm	143*20	Weight:kg	0.33	NO.	NO.59-19
Part No.	11509C-1707050																														
CH part name	焊接轴 (光)																														
EN part name	Welding shaft (light)																														
RU part name	Сварка вал (света)																														
Size:mm																															
Weight:kg	6.98																														
NO.	NO.59-9																														
Part No.	JS180-1707052																														
CH part name	副箱中间轴盖																														
EN part name	Intermediate shaft cover																														
RU part name	Промежуточный крышка																														
Size:mm	143*20																														
Weight:kg	0.33																														
NO.	NO.59-19																														
Remarks: SHACMAN 11509C		Remarks: SHACMAN																													
	<table border="1"> <tr><td>Part No.</td><td>81.27421.0129</td></tr> <tr><td>CH part name</td><td>车速里程表传感器</td></tr> <tr><td>EN part name</td><td>Speedometer sensor</td></tr> <tr><td>RU part name</td><td>Датчик спидометра</td></tr> <tr><td>Size:mm</td><td>1370*160*100</td></tr> <tr><td>Weight:kg</td><td>0.1</td></tr> <tr><td>NO.</td><td>NO.59-1-2</td></tr> </table>	Part No.	81.27421.0129	CH part name	车速里程表传感器	EN part name	Speedometer sensor	RU part name	Датчик спидометра	Size:mm	1370*160*100	Weight:kg	0.1	NO.	NO.59-1-2		<table border="1"> <tr><td>Part No.</td><td>JS180-1707154</td></tr> <tr><td>CH part name</td><td>主轴后轴承盖</td></tr> <tr><td>EN part name</td><td>After the bearing cover</td></tr> <tr><td>RU part name</td><td>Подшипник крышка после</td></tr> <tr><td>Size:mm</td><td></td></tr> <tr><td>Weight:kg</td><td>2.98</td></tr> <tr><td>NO.</td><td>NO.59-21</td></tr> </table>	Part No.	JS180-1707154	CH part name	主轴后轴承盖	EN part name	After the bearing cover	RU part name	Подшипник крышка после	Size:mm		Weight:kg	2.98	NO.	NO.59-21
Part No.	81.27421.0129																														
CH part name	车速里程表传感器																														
EN part name	Speedometer sensor																														
RU part name	Датчик спидометра																														
Size:mm	1370*160*100																														
Weight:kg	0.1																														
NO.	NO.59-1-2																														
Part No.	JS180-1707154																														
CH part name	主轴后轴承盖																														
EN part name	After the bearing cover																														
RU part name	Подшипник крышка после																														
Size:mm																															
Weight:kg	2.98																														
NO.	NO.59-21																														
Remarks: SHACMAN F3000 F2000 DZ9100583056 DZ9100580142		Remarks: SHACMAN 12JS160T 12JS200																													
	<table border="1"> <tr><td>Part No.</td><td>JS200-1707159-1</td></tr> <tr><td>CH part name</td><td>输出法兰盘</td></tr> <tr><td>EN part name</td><td>Output flange disc</td></tr> <tr><td>RU part name</td><td>результат фланец диск</td></tr> <tr><td>Size:mm</td><td></td></tr> <tr><td>Weight:kg</td><td>5.5</td></tr> <tr><td>NO.</td><td>NO.59-16</td></tr> </table>	Part No.	JS200-1707159-1	CH part name	输出法兰盘	EN part name	Output flange disc	RU part name	результат фланец диск	Size:mm		Weight:kg	5.5	NO.	NO.59-16		<table border="1"> <tr><td>Part No.</td><td>F91055</td></tr> <tr><td>CH part name</td><td>里程表被动齿轮</td></tr> <tr><td>EN part name</td><td>The passive gear</td></tr> <tr><td>RU part name</td><td>Пассивное зубчатое колесо</td></tr> <tr><td>Size:mm</td><td>65*48*6.2</td></tr> <tr><td>Weight:kg</td><td>0.01</td></tr> <tr><td>NO.</td><td>NO.59-2</td></tr> </table>	Part No.	F91055	CH part name	里程表被动齿轮	EN part name	The passive gear	RU part name	Пассивное зубчатое колесо	Size:mm	65*48*6.2	Weight:kg	0.01	NO.	NO.59-2
Part No.	JS200-1707159-1																														
CH part name	输出法兰盘																														
EN part name	Output flange disc																														
RU part name	результат фланец диск																														
Size:mm																															
Weight:kg	5.5																														
NO.	NO.59-16																														
Part No.	F91055																														
CH part name	里程表被动齿轮																														
EN part name	The passive gear																														
RU part name	Пассивное зубчатое колесо																														
Size:mm	65*48*6.2																														
Weight:kg	0.01																														
NO.	NO.59-2																														
Remarks: SHACMAN F3000 F2000		Remarks: SHACMAN 12JSD180TA 9JS119																													
	<table border="1"> <tr><td>Part No.</td><td>LF5-3802034</td></tr> <tr><td>CH part name</td><td>里程表被动齿轮</td></tr> <tr><td>EN part name</td><td>The passive gear</td></tr> <tr><td>RU part name</td><td>Пассивное зубчатое колесо</td></tr> <tr><td>Size:mm</td><td></td></tr> <tr><td>Weight:kg</td><td>0.15</td></tr> <tr><td>NO.</td><td>NO.59-2</td></tr> </table>	Part No.	LF5-3802034	CH part name	里程表被动齿轮	EN part name	The passive gear	RU part name	Пассивное зубчатое колесо	Size:mm		Weight:kg	0.15	NO.	NO.59-2		<table border="1"> <tr><td>Part No.</td><td>F91054</td></tr> <tr><td>CH part name</td><td>里程表主动齿轮</td></tr> <tr><td>EN part name</td><td>Driving gear</td></tr> <tr><td>RU part name</td><td>Ведущая шестерня</td></tr> <tr><td>Size:mm</td><td>130*120</td></tr> <tr><td>Weight:kg</td><td>0.2</td></tr> <tr><td>NO.</td><td>NO.59-1</td></tr> </table>	Part No.	F91054	CH part name	里程表主动齿轮	EN part name	Driving gear	RU part name	Ведущая шестерня	Size:mm	130*120	Weight:kg	0.2	NO.	NO.59-1
Part No.	LF5-3802034																														
CH part name	里程表被动齿轮																														
EN part name	The passive gear																														
RU part name	Пассивное зубчатое колесо																														
Size:mm																															
Weight:kg	0.15																														
NO.	NO.59-2																														
Part No.	F91054																														
CH part name	里程表主动齿轮																														
EN part name	Driving gear																														
RU part name	Ведущая шестерня																														
Size:mm	130*120																														
Weight:kg	0.2																														
NO.	NO.59-1																														
Remarks: SHACMAN 12JSD200TA		Remarks: SHACMAN 12JSD180TA 9JS119																													

SHACMAN(1)

	<table border="1"> <tr><td>Part No.</td><td>LF5-3802033</td></tr> <tr><td>CH part name</td><td>里程表主动齿轮</td></tr> <tr><td>EN part name</td><td>Driving gear</td></tr> <tr><td>RU part name</td><td>Ведущая шестерня</td></tr> <tr><td>Size:mm</td><td></td></tr> <tr><td>Weight:kg</td><td>0.2</td></tr> <tr><td>NO.</td><td>NO.59-1</td></tr> </table>	Part No.	LF5-3802033	CH part name	里程表主动齿轮	EN part name	Driving gear	RU part name	Ведущая шестерня	Size:mm		Weight:kg	0.2	NO.	NO.59-1		<table border="1"> <tr><td>Part No.</td><td>LF48-3802034</td></tr> <tr><td>CH part name</td><td>里程表被动齿轮</td></tr> <tr><td>EN part name</td><td>The passive gear</td></tr> <tr><td>RU part name</td><td>Пассивное зубчатое колесо</td></tr> <tr><td>Size:mm</td><td></td></tr> <tr><td>Weight:kg</td><td>0.015</td></tr> <tr><td>NO.</td><td>NO.59-2</td></tr> </table>	Part No.	LF48-3802034	CH part name	里程表被动齿轮	EN part name	The passive gear	RU part name	Пассивное зубчатое колесо	Size:mm		Weight:kg	0.015	NO.	NO.59-2
Part No.	LF5-3802033																														
CH part name	里程表主动齿轮																														
EN part name	Driving gear																														
RU part name	Ведущая шестерня																														
Size:mm																															
Weight:kg	0.2																														
NO.	NO.59-1																														
Part No.	LF48-3802034																														
CH part name	里程表被动齿轮																														
EN part name	The passive gear																														
RU part name	Пассивное зубчатое колесо																														
Size:mm																															
Weight:kg	0.015																														
NO.	NO.59-2																														
Remarks: SHACMAN 12JSD200TA		Remarks: SHACMAN 12JSD200TA																													
	<table border="1"> <tr><td>Part No.</td><td>14335</td></tr> <tr><td>CH part name</td><td>后盖衬垫</td></tr> <tr><td>EN part name</td><td>Lining for rear lid</td></tr> <tr><td>RU part name</td><td>Задняя прокладка</td></tr> <tr><td>Size:mm</td><td></td></tr> <tr><td>Weight:kg</td><td>0.01</td></tr> <tr><td>NO.</td><td>NO.59-24</td></tr> </table>	Part No.	14335	CH part name	后盖衬垫	EN part name	Lining for rear lid	RU part name	Задняя прокладка	Size:mm		Weight:kg	0.01	NO.	NO.59-24		<table border="1"> <tr><td>Part No.</td><td>LF48-3802033</td></tr> <tr><td>CH part name</td><td>里程表主动齿轮</td></tr> <tr><td>EN part name</td><td>Driving gear</td></tr> <tr><td>RU part name</td><td>Ведущая шестерня</td></tr> <tr><td>Size:mm</td><td></td></tr> <tr><td>Weight:kg</td><td>0.2</td></tr> <tr><td>NO.</td><td>NO.59-1</td></tr> </table>	Part No.	LF48-3802033	CH part name	里程表主动齿轮	EN part name	Driving gear	RU part name	Ведущая шестерня	Size:mm		Weight:kg	0.2	NO.	NO.59-1
Part No.	14335																														
CH part name	后盖衬垫																														
EN part name	Lining for rear lid																														
RU part name	Задняя прокладка																														
Size:mm																															
Weight:kg	0.01																														
NO.	NO.59-24																														
Part No.	LF48-3802033																														
CH part name	里程表主动齿轮																														
EN part name	Driving gear																														
RU part name	Ведущая шестерня																														
Size:mm																															
Weight:kg	0.2																														
NO.	NO.59-1																														
Remarks: SHACMAN 9JS150TA-B		Remarks: SHACMAN 12JSD200TA																													
	<table border="1"> <tr><td>Part No.</td><td>15532</td></tr> <tr><td>CH part name</td><td>副箱主轴后轴承盖衬垫</td></tr> <tr><td>EN part name</td><td>Vice shaft rear bearing cover gasket</td></tr> <tr><td>RU part name</td><td>Прокладка подшипника</td></tr> <tr><td>Size:mm</td><td></td></tr> <tr><td>Weight:kg</td><td>0.01</td></tr> <tr><td>NO.</td><td>NO.59-22</td></tr> </table>	Part No.	15532	CH part name	副箱主轴后轴承盖衬垫	EN part name	Vice shaft rear bearing cover gasket	RU part name	Прокладка подшипника	Size:mm		Weight:kg	0.01	NO.	NO.59-22		<table border="1"> <tr><td>Part No.</td><td>F99900-6</td></tr> <tr><td>CH part name</td><td>输出法兰盘</td></tr> <tr><td>EN part name</td><td>Output flange</td></tr> <tr><td>RU part name</td><td>Выходной фланец</td></tr> <tr><td>Size:mm</td><td></td></tr> <tr><td>Weight:kg</td><td>1.2</td></tr> <tr><td>NO.</td><td>NO.59-16</td></tr> </table>	Part No.	F99900-6	CH part name	输出法兰盘	EN part name	Output flange	RU part name	Выходной фланец	Size:mm		Weight:kg	1.2	NO.	NO.59-16
Part No.	15532																														
CH part name	副箱主轴后轴承盖衬垫																														
EN part name	Vice shaft rear bearing cover gasket																														
RU part name	Прокладка подшипника																														
Size:mm																															
Weight:kg	0.01																														
NO.	NO.59-22																														
Part No.	F99900-6																														
CH part name	输出法兰盘																														
EN part name	Output flange																														
RU part name	Выходной фланец																														
Size:mm																															
Weight:kg	1.2																														
NO.	NO.59-16																														
Remarks: SHACMAN 9JS150TA-B		Remarks: SHACMAN 9JS150TA-B																													
	<table border="1"> <tr><td>Part No.</td><td>F96119</td></tr> <tr><td>CH part name</td><td>防尘罩</td></tr> <tr><td>EN part name</td><td>Dust cover</td></tr> <tr><td>RU part name</td><td>пылеуловитель</td></tr> <tr><td>Size:mm</td><td></td></tr> <tr><td>Weight:kg</td><td>0.1</td></tr> <tr><td>NO.</td><td>NO.59-16</td></tr> </table>	Part No.	F96119	CH part name	防尘罩	EN part name	Dust cover	RU part name	пылеуловитель	Size:mm		Weight:kg	0.1	NO.	NO.59-16		<table border="1"> <tr><td>Part No.</td><td></td></tr> <tr><td>CH part name</td><td></td></tr> <tr><td>EN part name</td><td></td></tr> <tr><td>RU part name</td><td></td></tr> <tr><td>Size:mm</td><td></td></tr> <tr><td>Weight:kg</td><td></td></tr> <tr><td>NO.</td><td></td></tr> </table>	Part No.		CH part name		EN part name		RU part name		Size:mm		Weight:kg		NO.	
Part No.	F96119																														
CH part name	防尘罩																														
EN part name	Dust cover																														
RU part name	пылеуловитель																														
Size:mm																															
Weight:kg	0.1																														
NO.	NO.59-16																														
Part No.																															
CH part name																															
EN part name																															
RU part name																															
Size:mm																															
Weight:kg																															
NO.																															
Remarks: SHACMAN		Remarks: SHACMAN																													

SHACMAN(1)

	<table border="1"> <tr><td>Part No.</td><td>A-4740-1</td></tr> <tr><td>CH part name</td><td>空气滤清调节器总成</td></tr> <tr><td>EN part name</td><td>Air regulator valve</td></tr> <tr><td>RU part name</td><td>Регулятор очистки воздуха в сборе</td></tr> <tr><td>Size:mm</td><td>122*80*42</td></tr> <tr><td>Weight:kg</td><td>0.247</td></tr> <tr><td>NO.</td><td>NO.59-2</td></tr> </table>	Part No.	A-4740-1	CH part name	空气滤清调节器总成	EN part name	Air regulator valve	RU part name	Регулятор очистки воздуха в сборе	Size:mm	122*80*42	Weight:kg	0.247	NO.	NO.59-2		<table border="1"> <tr><td>Part No.</td><td>DZ9114312067</td></tr> <tr><td>CH part name</td><td>中后桥传动轴</td></tr> <tr><td>EN part name</td><td>Transmission shaft</td></tr> <tr><td>RU part name</td><td>Вал карданный ведущего моста в сборе</td></tr> <tr><td>Size:mm</td><td>67*180*180</td></tr> <tr><td>Weight:kg</td><td>33.4</td></tr> <tr><td>NO.</td><td>NO.60-9</td></tr> </table>	Part No.	DZ9114312067	CH part name	中后桥传动轴	EN part name	Transmission shaft	RU part name	Вал карданный ведущего моста в сборе	Size:mm	67*180*180	Weight:kg	33.4	NO.	NO.60-9
Part No.	A-4740-1																														
CH part name	空气滤清调节器总成																														
EN part name	Air regulator valve																														
RU part name	Регулятор очистки воздуха в сборе																														
Size:mm	122*80*42																														
Weight:kg	0.247																														
NO.	NO.59-2																														
Part No.	DZ9114312067																														
CH part name	中后桥传动轴																														
EN part name	Transmission shaft																														
RU part name	Вал карданный ведущего моста в сборе																														
Size:mm	67*180*180																														
Weight:kg	33.4																														
NO.	NO.60-9																														
Remarks: SHACMAN F3000 F2000		Remarks: SHACMAN F3000 F2000 DZ9114311067																													
	<table border="1"> <tr><td>Part No.</td><td>DZ9112312196</td></tr> <tr><td>CH part name</td><td>中间传动轴</td></tr> <tr><td>EN part name</td><td>Transmission shaft</td></tr> <tr><td>RU part name</td><td>Вал карданный ведущего моста в сборе</td></tr> <tr><td>Size:mm</td><td>1960*180*180</td></tr> <tr><td>Weight:kg</td><td>64</td></tr> <tr><td>NO.</td><td>NO.60-1</td></tr> </table>	Part No.	DZ9112312196	CH part name	中间传动轴	EN part name	Transmission shaft	RU part name	Вал карданный ведущего моста в сборе	Size:mm	1960*180*180	Weight:kg	64	NO.	NO.60-1		<table border="1"> <tr><td>Part No.</td><td>DZ9114311072</td></tr> <tr><td>CH part name</td><td>传动轴</td></tr> <tr><td>EN part name</td><td>Transmission shaft</td></tr> <tr><td>RU part name</td><td>Вал карданный ведущего моста в сборе</td></tr> <tr><td>Size:mm</td><td>730*180*180</td></tr> <tr><td>Weight:kg</td><td>34</td></tr> <tr><td>NO.</td><td>NO.60-9</td></tr> </table>	Part No.	DZ9114311072	CH part name	传动轴	EN part name	Transmission shaft	RU part name	Вал карданный ведущего моста в сборе	Size:mm	730*180*180	Weight:kg	34	NO.	NO.60-9
Part No.	DZ9112312196																														
CH part name	中间传动轴																														
EN part name	Transmission shaft																														
RU part name	Вал карданный ведущего моста в сборе																														
Size:mm	1960*180*180																														
Weight:kg	64																														
NO.	NO.60-1																														
Part No.	DZ9114311072																														
CH part name	传动轴																														
EN part name	Transmission shaft																														
RU part name	Вал карданный ведущего моста в сборе																														
Size:mm	730*180*180																														
Weight:kg	34																														
NO.	NO.60-9																														
Remarks: SHACMAN F3000 F2000 DZ9112312118/119/120		Remarks: SHACMAN F3000 F2000																													
	<table border="1"> <tr><td>Part No.</td><td>DZ9114313192</td></tr> <tr><td>CH part name</td><td>传动轴</td></tr> <tr><td>EN part name</td><td>Transmission shaft</td></tr> <tr><td>RU part name</td><td>Вал карданный ведущего моста в сборе</td></tr> <tr><td>Size:mm</td><td>1920*180*180</td></tr> <tr><td>Weight:kg</td><td>63</td></tr> <tr><td>NO.</td><td>NO.60-9</td></tr> </table>	Part No.	DZ9114313192	CH part name	传动轴	EN part name	Transmission shaft	RU part name	Вал карданный ведущего моста в сборе	Size:mm	1920*180*180	Weight:kg	63	NO.	NO.60-9		<table border="1"> <tr><td>Part No.</td><td>DZ91259312152</td></tr> <tr><td>CH part name</td><td>传动轴</td></tr> <tr><td>EN part name</td><td>Transmission shaft</td></tr> <tr><td>RU part name</td><td>Вал карданный ведущего моста в сборе</td></tr> <tr><td>Size:mm</td><td>1520*180*180</td></tr> <tr><td>Weight:kg</td><td>62</td></tr> <tr><td>NO.</td><td>NO.60-9</td></tr> </table>	Part No.	DZ91259312152	CH part name	传动轴	EN part name	Transmission shaft	RU part name	Вал карданный ведущего моста в сборе	Size:mm	1520*180*180	Weight:kg	62	NO.	NO.60-9
Part No.	DZ9114313192																														
CH part name	传动轴																														
EN part name	Transmission shaft																														
RU part name	Вал карданный ведущего моста в сборе																														
Size:mm	1920*180*180																														
Weight:kg	63																														
NO.	NO.60-9																														
Part No.	DZ91259312152																														
CH part name	传动轴																														
EN part name	Transmission shaft																														
RU part name	Вал карданный ведущего моста в сборе																														
Size:mm	1520*180*180																														
Weight:kg	62																														
NO.	NO.60-9																														
Remarks: SHACMAN F3000 F2000		Remarks: SHACMAN F3000 F2000 DZ9114313168																													
	<table border="1"> <tr><td>Part No.</td><td>DZ9112312072</td></tr> <tr><td>CH part name</td><td>传动轴</td></tr> <tr><td>EN part name</td><td>Transmission shaft</td></tr> <tr><td>RU part name</td><td>Вал карданный ведущего моста в сборе</td></tr> <tr><td>Size:mm</td><td>720*180*180</td></tr> <tr><td>Weight:kg</td><td>36</td></tr> <tr><td>NO.</td><td>NO.60-1</td></tr> </table>	Part No.	DZ9112312072	CH part name	传动轴	EN part name	Transmission shaft	RU part name	Вал карданный ведущего моста в сборе	Size:mm	720*180*180	Weight:kg	36	NO.	NO.60-1		<table border="1"> <tr><td>Part No.</td><td>DZ91189313902</td></tr> <tr><td>CH part name</td><td>传动轴凸缘叉Φ62</td></tr> <tr><td>EN part name</td><td>Flange fork</td></tr> <tr><td>RU part name</td><td>Вилка фланца</td></tr> <tr><td>Size:mm</td><td>180*180*120</td></tr> <tr><td>Weight:kg</td><td>3.5</td></tr> <tr><td>NO.</td><td>NO.60-1</td></tr> </table>	Part No.	DZ91189313902	CH part name	传动轴凸缘叉Φ62	EN part name	Flange fork	RU part name	Вилка фланца	Size:mm	180*180*120	Weight:kg	3.5	NO.	NO.60-1
Part No.	DZ9112312072																														
CH part name	传动轴																														
EN part name	Transmission shaft																														
RU part name	Вал карданный ведущего моста в сборе																														
Size:mm	720*180*180																														
Weight:kg	36																														
NO.	NO.60-1																														
Part No.	DZ91189313902																														
CH part name	传动轴凸缘叉Φ62																														
EN part name	Flange fork																														
RU part name	Вилка фланца																														
Size:mm	180*180*120																														
Weight:kg	3.5																														
NO.	NO.60-1																														
Remarks: SHACMAN F3000 F2000 DZ9112312073/76/84/88/90/91		Remarks: SHACMAN F3000 F2000																													

SHACMAN(1)

	<p>Part No. 19036311062</p> <p>CH part name 传动轴凸缘叉Φ57</p> <p>EN part name Flange fork</p> <p>RU part name Вилка фланца</p> <p>Size:mm 180*180*120</p> <p>Weight:kg 3.5</p> <p>NO. NO.60-1</p>		<p>Part No. P1122922000006-01</p> <p>CH part name 传动轴凸缘叉Φ57</p> <p>EN part name Flange fork</p> <p>RU part name Вилка фланца</p> <p>Size:mm 180*180*120</p> <p>Weight:kg 3.5</p> <p>NO. NO.60-1</p>
Remarks: SHACMAN F3000 F2000		Remarks: SHACMAN F3000 F2000 X3000 M3000	
	<p>Part No. P1120822080012-01</p> <p>CH part name 传动轴凸缘叉Φ52</p> <p>EN part name Flange fork</p> <p>RU part name Вилка фланца</p> <p>Size:mm 180*180*120</p> <p>Weight:kg 3.5</p> <p>NO. NO.60-1</p>		<p>Part No. P6564110011</p> <p>CH part name 传动轴凸缘叉Φ68</p> <p>EN part name Flange fork</p> <p>RU part name Вилка фланца</p> <p>Size:mm 180*180*120</p> <p>Weight:kg 3.5</p> <p>NO. NO.60-1</p>
Remarks: SHACMAN F3000 F2000 X3000 M3000		Remarks: SHACMAN F3000 F2000 X3000 M3000	
	<p>Part No. P635-2201-11</p> <p>CH part name 传动轴凸缘叉Φ63.5</p> <p>EN part name Flange fork</p> <p>RU part name Вилка фланца</p> <p>Size:mm 180*180*120</p> <p>Weight:kg 3.5</p> <p>NO. NO.60-1</p>		<p>Part No. PHWJ-707-00</p> <p>CH part name 万向节Φ68</p> <p>EN part name Universal joint assy.</p> <p>RU part name Креставина в сборе</p> <p>Size:mm 150*150*68</p> <p>Weight:kg 4.8</p> <p>NO. NO.60-3</p>
Remarks: SHACMAN F3000 F2000 X3000 M3000		Remarks: SHACMAN F3000 F2000 X3000 M3000	
	<p>Part No. P635-2201-18</p> <p>CH part name 万向节Φ63.5</p> <p>EN part name Universal joint assy.</p> <p>RU part name Креставина в сборе</p> <p>Size:mm 150*150*63.5</p> <p>Weight:kg 4.8</p> <p>NO. NO.60-3</p>		<p>Part No. HWJ-3276-00</p> <p>CH part name 万向节Φ57加长</p> <p>EN part name Universal joint assy.</p> <p>RU part name Креставина в сборе</p> <p>Size:mm 150.2*150.2*57</p> <p>Weight:kg 4.5</p> <p>NO. NO.60-3</p>
Remarks: SHACMAN F3000 F2000 X3000 M3000		Remarks: SHACMAN F3000 F2000 X3000 M3000	

SHACMAN(1)

	<table border="1"> <tr><td>Part No.</td><td>JS180-1701040-4</td></tr> <tr><td>CH part name</td><td>一轴轴承盖</td></tr> <tr><td>EN part name</td><td>Shaft bearing cap</td></tr> <tr><td>RU part name</td><td>Одна ось подшипник крышка</td></tr> <tr><td>Size:mm</td><td>170*170*170</td></tr> <tr><td>Weight:kg</td><td>2.28</td></tr> <tr><td>NO.</td><td>NO.A56-3</td></tr> </table>	Part No.	JS180-1701040-4	CH part name	一轴轴承盖	EN part name	Shaft bearing cap	RU part name	Одна ось подшипник крышка	Size:mm	170*170*170	Weight:kg	2.28	NO.	NO.A56-3		<table border="1"> <tr><td>Part No.</td><td>F91409</td></tr> <tr><td>CH part name</td><td>一轴轴承盖</td></tr> <tr><td>EN part name</td><td>Shaft bearing cap</td></tr> <tr><td>RU part name</td><td>Одна ось подшипник крышка</td></tr> <tr><td>Size:mm</td><td>170*170*170</td></tr> <tr><td>Weight:kg</td><td>2.05</td></tr> <tr><td>NO.</td><td>NO.56-3</td></tr> </table>	Part No.	F91409	CH part name	一轴轴承盖	EN part name	Shaft bearing cap	RU part name	Одна ось подшипник крышка	Size:mm	170*170*170	Weight:kg	2.05	NO.	NO.56-3
Part No.	JS180-1701040-4																														
CH part name	一轴轴承盖																														
EN part name	Shaft bearing cap																														
RU part name	Одна ось подшипник крышка																														
Size:mm	170*170*170																														
Weight:kg	2.28																														
NO.	NO.A56-3																														
Part No.	F91409																														
CH part name	一轴轴承盖																														
EN part name	Shaft bearing cap																														
RU part name	Одна ось подшипник крышка																														
Size:mm	170*170*170																														
Weight:kg	2.05																														
NO.	NO.56-3																														
Remarks:SHACMAN F2000 F3000		Remarks:SHACMAN RT-11509C																													
	<table border="1"> <tr><td>Part No.</td><td>F500A-1802191</td></tr> <tr><td>CH part name</td><td>轴承盖油封</td></tr> <tr><td>EN part name</td><td>Gearbox front oil seal</td></tr> <tr><td>RU part name</td><td>Сальник передний КПП</td></tr> <tr><td>Size:mm</td><td>70*70*8</td></tr> <tr><td>Weight:kg</td><td>0.08</td></tr> <tr><td>NO.</td><td>NO.A56-6</td></tr> </table>	Part No.	F500A-1802191	CH part name	轴承盖油封	EN part name	Gearbox front oil seal	RU part name	Сальник передний КПП	Size:mm	70*70*8	Weight:kg	0.08	NO.	NO.A56-6		<table border="1"> <tr><td>Part No.</td><td>F91410</td></tr> <tr><td>CH part name</td><td>轴承盖油封</td></tr> <tr><td>EN part name</td><td>Gearbox front oil seal</td></tr> <tr><td>RU part name</td><td>Сальник передний КПП</td></tr> <tr><td>Size:mm</td><td>47.5*65*6.5</td></tr> <tr><td>Weight:kg</td><td>0.02</td></tr> <tr><td>NO.</td><td>NO.56-6</td></tr> </table>	Part No.	F91410	CH part name	轴承盖油封	EN part name	Gearbox front oil seal	RU part name	Сальник передний КПП	Size:mm	47.5*65*6.5	Weight:kg	0.02	NO.	NO.56-6
Part No.	F500A-1802191																														
CH part name	轴承盖油封																														
EN part name	Gearbox front oil seal																														
RU part name	Сальник передний КПП																														
Size:mm	70*70*8																														
Weight:kg	0.08																														
NO.	NO.A56-6																														
Part No.	F91410																														
CH part name	轴承盖油封																														
EN part name	Gearbox front oil seal																														
RU part name	Сальник передний КПП																														
Size:mm	47.5*65*6.5																														
Weight:kg	0.02																														
NO.	NO.56-6																														
Remarks:SHACMAN F2000 F3000		Remarks:SHACMAN F2000 F3000 RT-11509C																													
	<table border="1"> <tr><td>Part No.</td><td>15410-17</td></tr> <tr><td>CH part name</td><td>离合器壳</td></tr> <tr><td>EN part name</td><td>Clutch housing</td></tr> <tr><td>RU part name</td><td>сцепление жилья</td></tr> <tr><td>Size:mm</td><td>500*500*250</td></tr> <tr><td>Weight:kg</td><td>42</td></tr> <tr><td>NO.</td><td>NO.A56-29</td></tr> </table>	Part No.	15410-17	CH part name	离合器壳	EN part name	Clutch housing	RU part name	сцепление жилья	Size:mm	500*500*250	Weight:kg	42	NO.	NO.A56-29		<table border="1"> <tr><td>Part No.</td><td>15410</td></tr> <tr><td>CH part name</td><td>离合器壳</td></tr> <tr><td>EN part name</td><td>Clutch housing</td></tr> <tr><td>RU part name</td><td>сцепление жилья</td></tr> <tr><td>Size:mm</td><td>500*500*250</td></tr> <tr><td>Weight:kg</td><td>39.5</td></tr> <tr><td>NO.</td><td>NO.56-22</td></tr> </table>	Part No.	15410	CH part name	离合器壳	EN part name	Clutch housing	RU part name	сцепление жилья	Size:mm	500*500*250	Weight:kg	39.5	NO.	NO.56-22
Part No.	15410-17																														
CH part name	离合器壳																														
EN part name	Clutch housing																														
RU part name	сцепление жилья																														
Size:mm	500*500*250																														
Weight:kg	42																														
NO.	NO.A56-29																														
Part No.	15410																														
CH part name	离合器壳																														
EN part name	Clutch housing																														
RU part name	сцепление жилья																														
Size:mm	500*500*250																														
Weight:kg	39.5																														
NO.	NO.56-22																														
Remarks:SHACMAN F3000 15410-17 9JS180		Remarks:SHACMAN RT-11509C 9JS119																													
	<table border="1"> <tr><td>Part No.</td><td>12JS160T-1701015</td></tr> <tr><td>CH part name</td><td>变速箱壳体</td></tr> <tr><td>EN part name</td><td>Transmission hull</td></tr> <tr><td>RU part name</td><td>передача корпус</td></tr> <tr><td>Size:mm</td><td>650*600*600</td></tr> <tr><td>Weight:kg</td><td>135</td></tr> <tr><td>NO.</td><td>NO.56-37</td></tr> </table>	Part No.	12JS160T-1701015	CH part name	变速箱壳体	EN part name	Transmission hull	RU part name	передача корпус	Size:mm	650*600*600	Weight:kg	135	NO.	NO.56-37		<table border="1"> <tr><td>Part No.</td><td>JS180-1601021-6</td></tr> <tr><td>CH part name</td><td>离合器拨叉</td></tr> <tr><td>EN part name</td><td>Release fork</td></tr> <tr><td>RU part name</td><td>Вилка выключения сцепления</td></tr> <tr><td>Size:mm</td><td>430*150*50</td></tr> <tr><td>Weight:kg</td><td>4</td></tr> <tr><td>NO.</td><td>NO.A56-21</td></tr> </table>	Part No.	JS180-1601021-6	CH part name	离合器拨叉	EN part name	Release fork	RU part name	Вилка выключения сцепления	Size:mm	430*150*50	Weight:kg	4	NO.	NO.A56-21
Part No.	12JS160T-1701015																														
CH part name	变速箱壳体																														
EN part name	Transmission hull																														
RU part name	передача корпус																														
Size:mm	650*600*600																														
Weight:kg	135																														
NO.	NO.56-37																														
Part No.	JS180-1601021-6																														
CH part name	离合器拨叉																														
EN part name	Release fork																														
RU part name	Вилка выключения сцепления																														
Size:mm	430*150*50																														
Weight:kg	4																														
NO.	NO.A56-21																														
Remarks:SHACMAN F3000 F2000		Remarks:SHACMAN F3000 F2000																													