

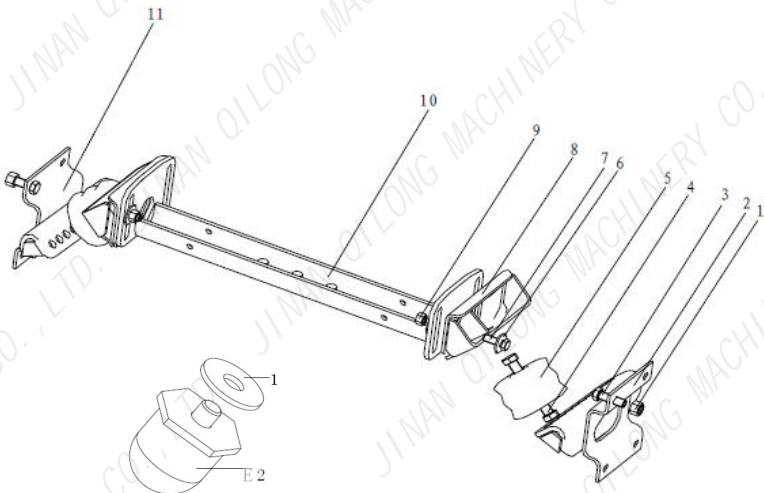









# SHACMAN(1)

GEAR BOX SUPPORT		NO.55															
		KD0932															
			<table border="1"> <tr><td>Part No.</td><td>DZ9112590885</td></tr> <tr><td>CH part name</td><td>横梁总成</td></tr> <tr><td>EN part name</td><td>Cross member assy</td></tr> <tr><td>RU part name</td><td>кросс - астрид</td></tr> <tr><td>Size:mm</td><td></td></tr> <tr><td>Weight:kg</td><td>4.8</td></tr> <tr><td>NO.</td><td><b>NO.55-10</b></td></tr> </table>	Part No.	DZ9112590885	CH part name	横梁总成	EN part name	Cross member assy	RU part name	кросс - астрид	Size:mm		Weight:kg	4.8	NO.	<b>NO.55-10</b>
Part No.	DZ9112590885																
CH part name	横梁总成																
EN part name	Cross member assy																
RU part name	кросс - астрид																
Size:mm																	
Weight:kg	4.8																
NO.	<b>NO.55-10</b>																
		Remarks:SHACMAN F3000 DZ95259590050															
		KD0933															
			<table border="1"> <tr><td>Part No.</td><td>DZ9118593004</td></tr> <tr><td>CH part name</td><td>横梁总成</td></tr> <tr><td>EN part name</td><td>Cross member assy</td></tr> <tr><td>RU part name</td><td>кросс - астрид</td></tr> <tr><td>Size:mm</td><td></td></tr> <tr><td>Weight:kg</td><td>4.8</td></tr> <tr><td>NO.</td><td><b>NO.55-10</b></td></tr> </table>	Part No.	DZ9118593004	CH part name	横梁总成	EN part name	Cross member assy	RU part name	кросс - астрид	Size:mm		Weight:kg	4.8	NO.	<b>NO.55-10</b>
Part No.	DZ9118593004																
CH part name	横梁总成																
EN part name	Cross member assy																
RU part name	кросс - астрид																
Size:mm																	
Weight:kg	4.8																
NO.	<b>NO.55-10</b>																
		Remarks:SHACMAN F3000															
KD0934																	
	<table border="1"> <tr><td>Part No.</td><td>AZ9112590099</td></tr> <tr><td>CH part name</td><td>变速器悬置横梁</td></tr> <tr><td>EN part name</td><td>Cross member assy</td></tr> <tr><td>RU part name</td><td>кросс - астрид</td></tr> <tr><td>Size:mm</td><td>6400*1700*820</td></tr> <tr><td>Weight:kg</td><td>5.02</td></tr> <tr><td>NO.</td><td><b>NO.55-10</b></td></tr> </table>	Part No.	AZ9112590099	CH part name	变速器悬置横梁	EN part name	Cross member assy	RU part name	кросс - астрид	Size:mm	6400*1700*820	Weight:kg	5.02	NO.	<b>NO.55-10</b>		
Part No.	AZ9112590099																
CH part name	变速器悬置横梁																
EN part name	Cross member assy																
RU part name	кросс - астрид																
Size:mm	6400*1700*820																
Weight:kg	5.02																
NO.	<b>NO.55-10</b>																
		Remarks:SHACMAN F2000 199112590100															
KD0935																	
	<table border="1"> <tr><td>Part No.</td><td>DZ9114590125</td></tr> <tr><td>CH part name</td><td>橡胶缓冲块</td></tr> <tr><td>EN part name</td><td>Rubber pad</td></tr> <tr><td>RU part name</td><td>резиновые фон</td></tr> <tr><td>Size:mm</td><td></td></tr> <tr><td>Weight:kg</td><td>0.32</td></tr> <tr><td>NO.</td><td><b>NO.55-5</b></td></tr> </table>	Part No.	DZ9114590125	CH part name	橡胶缓冲块	EN part name	Rubber pad	RU part name	резиновые фон	Size:mm		Weight:kg	0.32	NO.	<b>NO.55-5</b>		
Part No.	DZ9114590125																
CH part name	橡胶缓冲块																
EN part name	Rubber pad																
RU part name	резиновые фон																
Size:mm																	
Weight:kg	0.32																
NO.	<b>NO.55-5</b>																
		Remarks:SHACMAN F2000 F3000															
KD0936																	
	<table border="1"> <tr><td>Part No.</td><td>AZ9100591002</td></tr> <tr><td>CH part name</td><td>变速器辅助支承</td></tr> <tr><td>EN part name</td><td>Gear box assistant support</td></tr> <tr><td>RU part name</td><td>коробка передач помощник поддержки</td></tr> <tr><td>Size:mm</td><td></td></tr> <tr><td>Weight:kg</td><td>0.12</td></tr> <tr><td>NO.</td><td><b>NO.55-E2</b></td></tr> </table>	Part No.	AZ9100591002	CH part name	变速器辅助支承	EN part name	Gear box assistant support	RU part name	коробка передач помощник поддержки	Size:mm		Weight:kg	0.12	NO.	<b>NO.55-E2</b>		
Part No.	AZ9100591002																
CH part name	变速器辅助支承																
EN part name	Gear box assistant support																
RU part name	коробка передач помощник поддержки																
Size:mm																	
Weight:kg	0.12																
NO.	<b>NO.55-E2</b>																
		Remarks:SHACMAN F2000															
KD0937																	
	<table border="1"> <tr><td>Part No.</td><td>ZQC2000</td></tr> <tr><td>CH part name</td><td>分动箱</td></tr> <tr><td>EN part name</td><td>TRANSFER GEAR BOX</td></tr> <tr><td>RU part name</td><td>передача коробки передач</td></tr> <tr><td>Size:mm</td><td></td></tr> <tr><td>Weight:kg</td><td>195</td></tr> <tr><td>NO.</td><td></td></tr> </table>	Part No.	ZQC2000	CH part name	分动箱	EN part name	TRANSFER GEAR BOX	RU part name	передача коробки передач	Size:mm		Weight:kg	195	NO.			
Part No.	ZQC2000																
CH part name	分动箱																
EN part name	TRANSFER GEAR BOX																
RU part name	передача коробки передач																
Size:mm																	
Weight:kg	195																
NO.																	
		Remarks:SHACMAN F2000 F3000 8*4															

# SHACMAN(1)

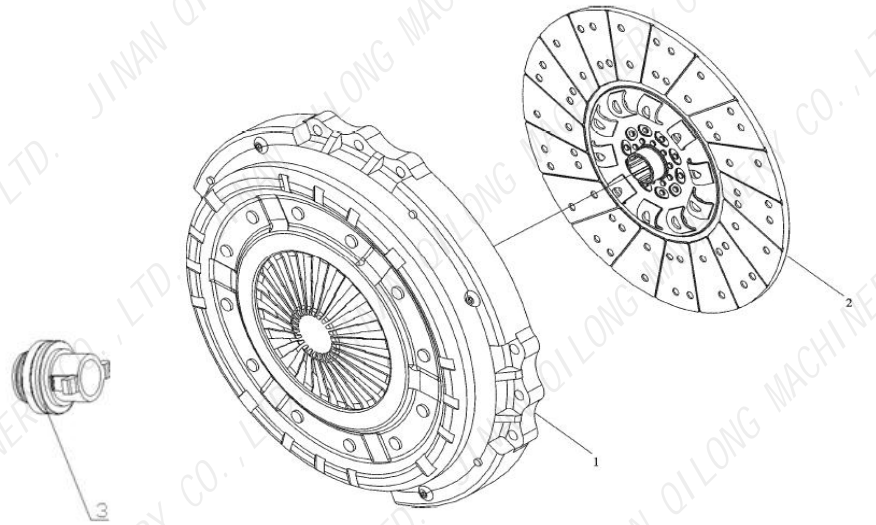
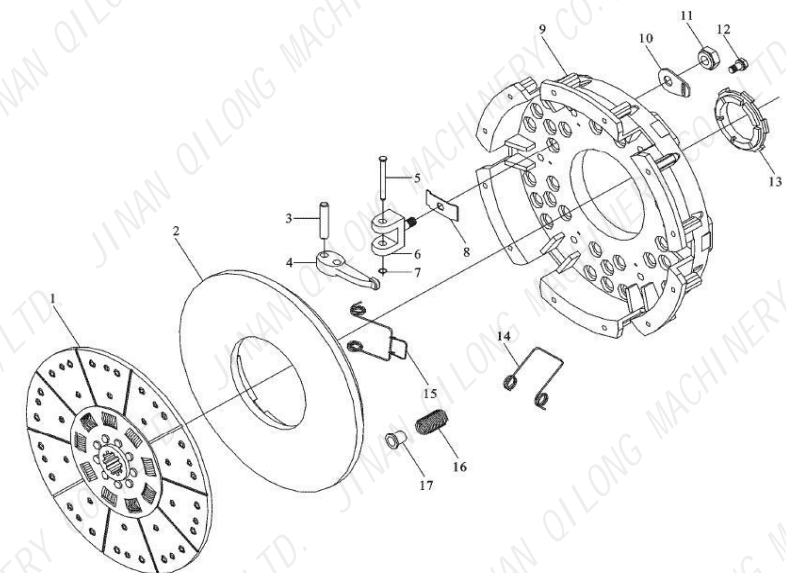
PULL DIAPHRAGM CLUTCH		NO.49																													
		KD0852																													
			<table border="1"> <tr><td>Part No.</td><td>DZ9114160035</td></tr> <tr><td>CH part name</td><td>拉式分离轴承</td></tr> <tr><td>EN part name</td><td>Release bearing with seat</td></tr> <tr><td>RU part name</td><td>Выжимной подшипник</td></tr> <tr><td>Size:mm</td><td>155*155*120</td></tr> <tr><td>Weight:kg</td><td>2.9</td></tr> <tr><td>NO.O</td><td><b>NO.49-3</b></td></tr> </table>	Part No.	DZ9114160035	CH part name	拉式分离轴承	EN part name	Release bearing with seat	RU part name	Выжимной подшипник	Size:mm	155*155*120	Weight:kg	2.9	NO.O	<b>NO.49-3</b>														
		Part No.	DZ9114160035																												
		CH part name	拉式分离轴承																												
EN part name	Release bearing with seat																														
RU part name	Выжимной подшипник																														
Size:mm	155*155*120																														
Weight:kg	2.9																														
NO.O	<b>NO.49-3</b>																														
Remarks: SHACMAN F2000 F3000 DZ9114160023 DZ9114160044 DZ9112210015																															
KD0853			<table border="1"> <tr><td>Part No.</td><td>DZ9114160026</td></tr> <tr><td>CH part name</td><td>430推式压盘总成</td></tr> <tr><td>EN part name</td><td>430 Platen assy.</td></tr> <tr><td>RU part name</td><td>Корзина сцепления 430 в сборе</td></tr> <tr><td>Size:mm</td><td>500*500*130</td></tr> <tr><td>Weight:kg</td><td>38</td></tr> <tr><td>NO.</td><td><b>NO.50-1</b></td></tr> </table>	Part No.	DZ9114160026	CH part name	430推式压盘总成	EN part name	430 Platen assy.	RU part name	Корзина сцепления 430 в сборе	Size:mm	500*500*130	Weight:kg	38	NO.	<b>NO.50-1</b>														
Part No.	DZ9114160026																														
CH part name	430推式压盘总成																														
EN part name	430 Platen assy.																														
RU part name	Корзина сцепления 430 в сборе																														
Size:mm	500*500*130																														
Weight:kg	38																														
NO.	<b>NO.50-1</b>																														
Remarks: SHACMAN F2000 F3000 DZ9114160028																															
KD0854		KD0855																													
	<table border="1"> <tr><td>Part No.</td><td>161560160001</td></tr> <tr><td>CH part name</td><td>推式从动盘</td></tr> <tr><td>EN part name</td><td>420 Clutch disc</td></tr> <tr><td>RU part name</td><td>Диск сцепления</td></tr> <tr><td>Size:mm</td><td>420*420*65</td></tr> <tr><td>Weight:kg</td><td>8.45</td></tr> <tr><td>NO.</td><td><b>NO.50-2</b></td></tr> </table>	Part No.	161560160001	CH part name	推式从动盘	EN part name	420 Clutch disc	RU part name	Диск сцепления	Size:mm	420*420*65	Weight:kg	8.45	NO.	<b>NO.50-2</b>		<table border="1"> <tr><td>Part No.</td><td>161560160001</td></tr> <tr><td>CH part name</td><td>推式从动盘</td></tr> <tr><td>EN part name</td><td>420 Clutch disc</td></tr> <tr><td>RU part name</td><td>Диск сцепления</td></tr> <tr><td>Size:mm</td><td>420*420*65</td></tr> <tr><td>Weight:kg</td><td>8.45</td></tr> <tr><td>NO.</td><td><b>NO.50-2</b></td></tr> </table>	Part No.	161560160001	CH part name	推式从动盘	EN part name	420 Clutch disc	RU part name	Диск сцепления	Size:mm	420*420*65	Weight:kg	8.45	NO.	<b>NO.50-2</b>
Part No.	161560160001																														
CH part name	推式从动盘																														
EN part name	420 Clutch disc																														
RU part name	Диск сцепления																														
Size:mm	420*420*65																														
Weight:kg	8.45																														
NO.	<b>NO.50-2</b>																														
Part No.	161560160001																														
CH part name	推式从动盘																														
EN part name	420 Clutch disc																														
RU part name	Диск сцепления																														
Size:mm	420*420*65																														
Weight:kg	8.45																														
NO.	<b>NO.50-2</b>																														
Remarks: SHACMAN F2000		Remarks: SHACMAN F2000																													
KD0856		KD0857																													
	<table border="1"> <tr><td>Part No.</td><td>DZ9114160034FLH3</td></tr> <tr><td>CH part name</td><td>分离环</td></tr> <tr><td>EN part name</td><td>Ring</td></tr> <tr><td>RU part name</td><td>кольцо</td></tr> <tr><td>Size:mm</td><td></td></tr> <tr><td>Weight:kg</td><td>0.12</td></tr> <tr><td>NO.</td><td><b>NO.49-4</b></td></tr> </table>	Part No.	DZ9114160034FLH3	CH part name	分离环	EN part name	Ring	RU part name	кольцо	Size:mm		Weight:kg	0.12	NO.	<b>NO.49-4</b>		<table border="1"> <tr><td>Part No.</td><td>DZ9114160034FLH6</td></tr> <tr><td>CH part name</td><td>分离环</td></tr> <tr><td>EN part name</td><td>Ring</td></tr> <tr><td>RU part name</td><td>кольцо</td></tr> <tr><td>Size:mm</td><td></td></tr> <tr><td>Weight:kg</td><td>0.15</td></tr> <tr><td>NO.</td><td><b>NO.49-4</b></td></tr> </table>	Part No.	DZ9114160034FLH6	CH part name	分离环	EN part name	Ring	RU part name	кольцо	Size:mm		Weight:kg	0.15	NO.	<b>NO.49-4</b>
Part No.	DZ9114160034FLH3																														
CH part name	分离环																														
EN part name	Ring																														
RU part name	кольцо																														
Size:mm																															
Weight:kg	0.12																														
NO.	<b>NO.49-4</b>																														
Part No.	DZ9114160034FLH6																														
CH part name	分离环																														
EN part name	Ring																														
RU part name	кольцо																														
Size:mm																															
Weight:kg	0.15																														
NO.	<b>NO.49-4</b>																														
Remarks: SHACMAN F2000 F3000		Remarks: SHACMAN F2000 F3000																													

# SHACMAN(1)

PUSH DIAPHRAGM CLUTCH NO.50			PUSH DIAPHRAGM CLUTCH NO.A50		
					
KD0858			KD0859		
	Part No.	BZ1560161212		Part No.	BZ1560161096
	CH part name	分离环		CH part name	离合器分离杆
	EN part name	Ring		EN part name	Separation lever assembly
	RU part name	кольцо		RU part name	разделение рычаг в сборе
	Size:mm			Size:mm	
	Weight:kg	0.3		Weight:kg	0.04
	NO.	<b>NO.A50-13</b>		NO.	<b>NO.A50-4</b>
Remarks:SHACMAN F2000 奥龙			Remarks:SHACMAN F2000 奥龙		
KD0860			KD0861		
	Part No.	199114160013		Part No.	DZ9112210015
	CH part name	膜片压盘420		CH part name	推式分离轴承
	EN part name	Platen		EN part name	Release bearing
	RU part name	Корзина сцепления		RU part name	Выжимной подшипник
	Size:mm	480*480*110		Size:mm	155*155*120
	Weight:kg	50.15		Weight:kg	2.5
	NO.	<b>NO.A50</b>		NO.	<b>NO.50-3</b>
Remarks: SHACMAN F2000 BZ1560161090			Remarks: SHACMAN F2000 F3000		





# SHACMAN(1)

	<table border="1"> <tr><td>Part No.</td><td>DZ9112230166</td></tr> <tr><td>CH part name</td><td>推式离合器助力器</td></tr> <tr><td>EN part name</td><td>Operating cylinder</td></tr> <tr><td>RU part name</td><td>Усилитель сцепления</td></tr> <tr><td>Size:mm</td><td>260*110*110</td></tr> <tr><td>Weight:kg</td><td>2.45</td></tr> <tr><td>NO.</td><td><b>NO.B51-6</b></td></tr> </table>	Part No.	DZ9112230166	CH part name	推式离合器助力器	EN part name	Operating cylinder	RU part name	Усилитель сцепления	Size:mm	260*110*110	Weight:kg	2.45	NO.	<b>NO.B51-6</b>		<table border="1"> <tr><td>Part No.</td><td>DZ9112230020</td></tr> <tr><td>CH part name</td><td>推式分离摇臂</td></tr> <tr><td>EN part name</td><td>Release arm</td></tr> <tr><td>RU part name</td><td>Выжимной рычаг</td></tr> <tr><td>Size:mm</td><td>280*130*65</td></tr> <tr><td>Weight:kg</td><td>1.35</td></tr> <tr><td>NO.</td><td><b>NO.B51-1</b></td></tr> </table>	Part No.	DZ9112230020	CH part name	推式分离摇臂	EN part name	Release arm	RU part name	Выжимной рычаг	Size:mm	280*130*65	Weight:kg	1.35	NO.	<b>NO.B51-1</b>
Part No.	DZ9112230166																														
CH part name	推式离合器助力器																														
EN part name	Operating cylinder																														
RU part name	Усилитель сцепления																														
Size:mm	260*110*110																														
Weight:kg	2.45																														
NO.	<b>NO.B51-6</b>																														
Part No.	DZ9112230020																														
CH part name	推式分离摇臂																														
EN part name	Release arm																														
RU part name	Выжимной рычаг																														
Size:mm	280*130*65																														
Weight:kg	1.35																														
NO.	<b>NO.B51-1</b>																														
Remarks: SHACMAN F2000 F3000		Remarks: SHACMAN F2000 F3000																													
	<table border="1"> <tr><td>Part No.</td><td>DZ93189230080</td></tr> <tr><td>CH part name</td><td>整体式离合器分泵</td></tr> <tr><td>EN part name</td><td>Operating cylinder</td></tr> <tr><td>RU part name</td><td>Усилитель сцепления</td></tr> <tr><td>Size:mm</td><td></td></tr> <tr><td>Weight:kg</td><td>2.45</td></tr> <tr><td>NO.</td><td><b>NO.B51-6</b></td></tr> </table>	Part No.	DZ93189230080	CH part name	整体式离合器分泵	EN part name	Operating cylinder	RU part name	Усилитель сцепления	Size:mm		Weight:kg	2.45	NO.	<b>NO.B51-6</b>		<table border="1"> <tr><td>Part No.</td><td>DZ96259230420</td></tr> <tr><td>CH part name</td><td>离合器油管</td></tr> <tr><td>EN part name</td><td>Tube</td></tr> <tr><td>RU part name</td><td>Шланг</td></tr> <tr><td>Size:mm</td><td>4200*30*30</td></tr> <tr><td>Weight:kg</td><td>0.8</td></tr> <tr><td>NO.</td><td><b>NO.B51-11</b></td></tr> </table>	Part No.	DZ96259230420	CH part name	离合器油管	EN part name	Tube	RU part name	Шланг	Size:mm	4200*30*30	Weight:kg	0.8	NO.	<b>NO.B51-11</b>
Part No.	DZ93189230080																														
CH part name	整体式离合器分泵																														
EN part name	Operating cylinder																														
RU part name	Усилитель сцепления																														
Size:mm																															
Weight:kg	2.45																														
NO.	<b>NO.B51-6</b>																														
Part No.	DZ96259230420																														
CH part name	离合器油管																														
EN part name	Tube																														
RU part name	Шланг																														
Size:mm	4200*30*30																														
Weight:kg	0.8																														
NO.	<b>NO.B51-11</b>																														
Remarks: SHACMAN		Remarks: SHACMAN F2000 F3000 DZ9112230011 DZ93259230254																													
	<table border="1"> <tr><td>Part No.</td><td>DZ9112230166</td></tr> <tr><td>CH part name</td><td>推式离合器助力器</td></tr> <tr><td>EN part name</td><td>Operating cylinder</td></tr> <tr><td>RU part name</td><td>Усилитель сцепления</td></tr> <tr><td>Size:mm</td><td>290*120*120</td></tr> <tr><td>Weight:kg</td><td>2.6</td></tr> <tr><td>NO.</td><td><b>NO.B51-6</b></td></tr> </table>	Part No.	DZ9112230166	CH part name	推式离合器助力器	EN part name	Operating cylinder	RU part name	Усилитель сцепления	Size:mm	290*120*120	Weight:kg	2.6	NO.	<b>NO.B51-6</b>		<table border="1"> <tr><td>Part No.</td><td>DZ95259230420</td></tr> <tr><td>CH part name</td><td>拉式离合器分泵油管</td></tr> <tr><td>EN part name</td><td>Tube</td></tr> <tr><td>RU part name</td><td>Шланг</td></tr> <tr><td>Size:mm</td><td>4200*30*30</td></tr> <tr><td>Weight:kg</td><td>0.8</td></tr> <tr><td>NO.</td><td><b>NO.51-3</b></td></tr> </table>	Part No.	DZ95259230420	CH part name	拉式离合器分泵油管	EN part name	Tube	RU part name	Шланг	Size:mm	4200*30*30	Weight:kg	0.8	NO.	<b>NO.51-3</b>
Part No.	DZ9112230166																														
CH part name	推式离合器助力器																														
EN part name	Operating cylinder																														
RU part name	Усилитель сцепления																														
Size:mm	290*120*120																														
Weight:kg	2.6																														
NO.	<b>NO.B51-6</b>																														
Part No.	DZ95259230420																														
CH part name	拉式离合器分泵油管																														
EN part name	Tube																														
RU part name	Шланг																														
Size:mm	4200*30*30																														
Weight:kg	0.8																														
NO.	<b>NO.51-3</b>																														
Remarks: SHACMAN F3000		Remarks: SHACMAN F2000 F3000 DZ9112230009																													
	<table border="1"> <tr><td>Part No.</td><td>DZ93189230090</td></tr> <tr><td>CH part name</td><td>离合器总泵</td></tr> <tr><td>EN part name</td><td>Operating cylinder</td></tr> <tr><td>RU part name</td><td>Усилитель сцепления</td></tr> <tr><td>Size:mm</td><td>160*180*53</td></tr> <tr><td>Weight:kg</td><td>0.83</td></tr> <tr><td>NO.</td><td><b>NO.51-11</b></td></tr> </table>	Part No.	DZ93189230090	CH part name	离合器总泵	EN part name	Operating cylinder	RU part name	Усилитель сцепления	Size:mm	160*180*53	Weight:kg	0.83	NO.	<b>NO.51-11</b>		<table border="1"> <tr><td>Part No.</td><td>DZ9112230178</td></tr> <tr><td>CH part name</td><td>拉式离合器助力器</td></tr> <tr><td>EN part name</td><td>Operating cylinder</td></tr> <tr><td>RU part name</td><td>Усилитель сцепления</td></tr> <tr><td>Size:mm</td><td>310*110*110</td></tr> <tr><td>Weight:kg</td><td>2.6</td></tr> <tr><td>NO.</td><td><b>NO.51-9</b></td></tr> </table>	Part No.	DZ9112230178	CH part name	拉式离合器助力器	EN part name	Operating cylinder	RU part name	Усилитель сцепления	Size:mm	310*110*110	Weight:kg	2.6	NO.	<b>NO.51-9</b>
Part No.	DZ93189230090																														
CH part name	离合器总泵																														
EN part name	Operating cylinder																														
RU part name	Усилитель сцепления																														
Size:mm	160*180*53																														
Weight:kg	0.83																														
NO.	<b>NO.51-11</b>																														
Part No.	DZ9112230178																														
CH part name	拉式离合器助力器																														
EN part name	Operating cylinder																														
RU part name	Усилитель сцепления																														
Size:mm	310*110*110																														
Weight:kg	2.6																														
NO.	<b>NO.51-9</b>																														
Remarks: SHACMAN F2000 F3000		Remarks: SHACMAN F2000 F3000																													

# SHACMAN(1)

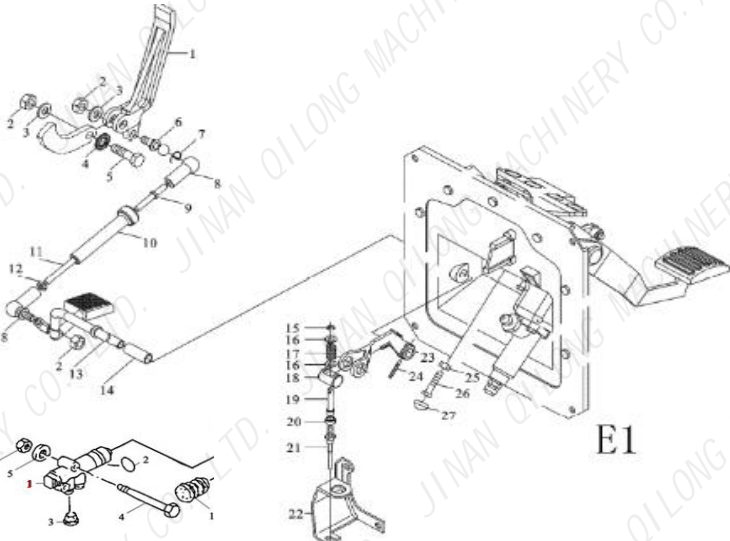
PULL CLUTCH CONTROL DEVICE			NO.51			PUSH CLUTCH CONTROL DEVICE			NO.B51		
KD0870						KD0871					
	Part No.	DZ9112230181					Part No.	DZ9114230020			
	CH part name	拉式离合器助力器					CH part name	德龙离合器总成			
	EN part name	Operating cylinder					EN part name	Clutch master cylinder			
	RU part name	Усилитель сцепления					RU part name	Цилиндр главный сцепления			
	Size:mm	290*120*120					Size:mm	160*180*53			
	Weight:kg	2.6					Weight:kg	0.9			
	NO.	<b>NO.51-9</b>					NO.	<b>NO.B51-13</b>			
Remarks:SHACMAN F3000						Remarks:SHACMAN F2000 F3000					
KD0872						KD0873					
	Part No.	DZ97189230500					Part No.	DZ9114230021			
	CH part name	踏板机构总成 EGR					CH part name	离合器总泵储液罐			
	EN part name	Pedal mechanism					EN part name	Clutch master cylinder tanker			
	RU part name	механизма педали					RU part name	Главный гидронасос сцепления			
	Size:mm						Size:mm	230*230*250			
	Weight:kg	15					Weight:kg	0.03			
	NO.	<b>NO.52-E1</b>					NO.	<b>NO.B51-14</b>			
Remarks:SHACMAN F3000 M3000 新M3000 DZ97189230510						Remarks:SHACMAN F2000 F3000					

# SHACMAN(1)

CONTROL VALVE WITH /OPERATING MECHANISM		NO.52		
			KD0874	
				
		Remarks: SHACMAN F2000 奥龙 DZ9112230001 81.48220.0106		
		KD0875		
				
		Remarks:SHACMAN M3000国II改进型		
KD0876			KD0877	
	Part No.	81.52170.6156	Part No.	DZ92189230310
	CH part name	离合器操纵控阀	CH part name	踏板机构总成
	EN part name	Manipulating valve	EN part name	Pedal mechanism
	RU part name	Клапан сцепления пневматический	RU part name	механизма педали
	Size:mm	72*56*22	Size:mm	
	Weight:kg	0.13	Weight:kg	15
	NO.	<b>NO.52-1</b>	NO.	<b>NO.52-E1</b>
Remarks:SHACMAN F2000 F3000		Remarks:SHACMAN F2000 F3000 奥龙		
KD0878			KD0879	
	Part No.	DZ93259240094	Part No.	81.32670.6184
	CH part name	9档变速杆总成	CH part name	变速杆总成9档
	EN part name	Shift rod assy.	EN part name	Shift rod assy.
	RU part name	Рычаг переключения скорости в сборе	RU part name	Рычаг переключения скорости в сборе
	Size:mm	550*260*260	Size:mm	500*260*260
	Weight:kg	3.75	Weight:kg	4.05
	NO.	<b>NO.53-3</b>	NO.	<b>NO.53-3</b>
Remarks:SHACMAN F2000 F3000 加长50		Remarks:SHACMAN F2000 F3000		

# SHACMAN(1)

SHIFTING DEVECE		NO.53															
		KD0880															
			<table border="1"> <tr><td>Part No.</td><td>DZ93259246184</td></tr> <tr><td>CH part name</td><td>变速杆总成</td></tr> <tr><td>EN part name</td><td>Shift rod assy.</td></tr> <tr><td>RU part name</td><td>Рычаг переключения скорости в сборе</td></tr> <tr><td>Size:mm</td><td>500*260*260</td></tr> <tr><td>Weight:kg</td><td>4.05</td></tr> <tr><td>NO.</td><td><b>NO.53-3</b></td></tr> </table>	Part No.	DZ93259246184	CH part name	变速杆总成	EN part name	Shift rod assy.	RU part name	Рычаг переключения скорости в сборе	Size:mm	500*260*260	Weight:kg	4.05	NO.	<b>NO.53-3</b>
		Part No.	DZ93259246184														
		CH part name	变速杆总成														
		EN part name	Shift rod assy.														
		RU part name	Рычаг переключения скорости в сборе														
		Size:mm	500*260*260														
		Weight:kg	4.05														
		NO.	<b>NO.53-3</b>														
		Remarks:SHACMAN F2000 F3000															
KD0881																	
	<table border="1"> <tr><td>Part No.</td><td>SZ924000743</td></tr> <tr><td>CH part name</td><td>9档变速杆总成</td></tr> <tr><td>EN part name</td><td>Shift rod assy.</td></tr> <tr><td>RU part name</td><td>Рычаг переключения скорости в сборе</td></tr> <tr><td>Size:mm</td><td>500*260*260</td></tr> <tr><td>Weight:kg</td><td>3.9</td></tr> <tr><td>NO.</td><td><b>NO.53-3</b></td></tr> </table>	Part No.	SZ924000743	CH part name	9档变速杆总成	EN part name	Shift rod assy.	RU part name	Рычаг переключения скорости в сборе	Size:mm	500*260*260	Weight:kg	3.9	NO.	<b>NO.53-3</b>		
Part No.	SZ924000743																
CH part name	9档变速杆总成																
EN part name	Shift rod assy.																
RU part name	Рычаг переключения скорости в сборе																
Size:mm	500*260*260																
Weight:kg	3.9																
NO.	<b>NO.53-3</b>																
Remarks:SHACMAN F2000 F3000																	
KD0882																	
	<table border="1"> <tr><td>Part No.</td><td>SZ924000862</td></tr> <tr><td>CH part name</td><td>换挡杆总成</td></tr> <tr><td>EN part name</td><td>Shift rod assy.</td></tr> <tr><td>RU part name</td><td>Рычаг переключения скорости в сборе</td></tr> <tr><td>Size:mm</td><td>500*260*260</td></tr> <tr><td>Weight:kg</td><td>3.75</td></tr> <tr><td>NO.</td><td><b>NO.53-3</b></td></tr> </table>	Part No.	SZ924000862	CH part name	换挡杆总成	EN part name	Shift rod assy.	RU part name	Рычаг переключения скорости в сборе	Size:mm	500*260*260	Weight:kg	3.75	NO.	<b>NO.53-3</b>		
Part No.	SZ924000862																
CH part name	换挡杆总成																
EN part name	Shift rod assy.																
RU part name	Рычаг переключения скорости в сборе																
Size:mm	500*260*260																
Weight:kg	3.75																
NO.	<b>NO.53-3</b>																
Remarks:SHACMAN F3000																	
KD0883																	
	<table border="1"> <tr><td>Part No.</td><td>DZ93259240066</td></tr> <tr><td>CH part name</td><td>换挡杆总成12档</td></tr> <tr><td>EN part name</td><td>Shift rod assy.</td></tr> <tr><td>RU part name</td><td>Рычаг переключения скорости в сборе</td></tr> <tr><td>Size:mm</td><td>500*260*260</td></tr> <tr><td>Weight:kg</td><td>3.75</td></tr> <tr><td>NO.</td><td><b>NO.53-3</b></td></tr> </table>	Part No.	DZ93259240066	CH part name	换挡杆总成12档	EN part name	Shift rod assy.	RU part name	Рычаг переключения скорости в сборе	Size:mm	500*260*260	Weight:kg	3.75	NO.	<b>NO.53-3</b>		
Part No.	DZ93259240066																
CH part name	换挡杆总成12档																
EN part name	Shift rod assy.																
RU part name	Рычаг переключения скорости в сборе																
Size:mm	500*260*260																
Weight:kg	3.75																
NO.	<b>NO.53-3</b>																
Remarks:SHACMAN F3000 DZ9114240026																	
KD0884																	
	<table border="1"> <tr><td>Part No.</td><td>DZ9112240028</td></tr> <tr><td>CH part name</td><td>换挡操纵杆</td></tr> <tr><td>EN part name</td><td>Vertical rod assy.</td></tr> <tr><td>RU part name</td><td>Тяга рычага переключения скоростей</td></tr> <tr><td>Size:mm</td><td>1450*180*40</td></tr> <tr><td>Weight:kg</td><td>3.8</td></tr> <tr><td>NO.</td><td><b>NO.53-11</b></td></tr> </table>	Part No.	DZ9112240028	CH part name	换挡操纵杆	EN part name	Vertical rod assy.	RU part name	Тяга рычага переключения скоростей	Size:mm	1450*180*40	Weight:kg	3.8	NO.	<b>NO.53-11</b>		
Part No.	DZ9112240028																
CH part name	换挡操纵杆																
EN part name	Vertical rod assy.																
RU part name	Тяга рычага переключения скоростей																
Size:mm	1450*180*40																
Weight:kg	3.8																
NO.	<b>NO.53-11</b>																
Remarks:SHACMAN F2000 F3000																	
KD0885																	
	<table border="1"> <tr><td>Part No.</td><td>DZ95259240015</td></tr> <tr><td>CH part name</td><td>换挡操纵杆</td></tr> <tr><td>EN part name</td><td>Vertical rod assy.</td></tr> <tr><td>RU part name</td><td>Тяга рычага переключения скоростей</td></tr> <tr><td>Size:mm</td><td></td></tr> <tr><td>Weight:kg</td><td>3.6</td></tr> <tr><td>NO.</td><td><b>NO.53-11</b></td></tr> </table>	Part No.	DZ95259240015	CH part name	换挡操纵杆	EN part name	Vertical rod assy.	RU part name	Тяга рычага переключения скоростей	Size:mm		Weight:kg	3.6	NO.	<b>NO.53-11</b>		
Part No.	DZ95259240015																
CH part name	换挡操纵杆																
EN part name	Vertical rod assy.																
RU part name	Тяга рычага переключения скоростей																
Size:mm																	
Weight:kg	3.6																
NO.	<b>NO.53-11</b>																
Remarks:SHACMAN F2000 F3000																	

# SHACMAN(1)







KD0886			KD0887		
	Part No.	DZ96259240585		Part No.	DZ96259240515
	CH part name	伸缩拉杆总成		CH part name	换挡操纵杆
	EN part name	Vertical rod assy.		EN part name	Vertical rod assy.
	RU part name	Тяга рычага переключения скоростей		RU part name	Тяга рычага переключения скоростей
	Size:mm			Size:mm	
	Weight:kg	5.2		Weight:kg	3.8
	NO.	<b>NO.53-11</b>		NO.	<b>NO.53-11</b>
Remarks:SHACMAN M3000			Remarks:SHACMAN M3000		
KD0888			KD0889		
	Part No.	DZ96259240524		Part No.	DZ96259240525
	CH part name	换挡杆支架		CH part name	换挡操纵杆
	EN part name	Bracket		EN part name	Vertical rod assy.
	RU part name	кронштейн		RU part name	Тяга рычага переключения скоростей
	Size:mm			Size:mm	
	Weight:kg	1.5		Weight:kg	3.5
	NO.	<b>NO.53-2</b>		NO.	<b>NO.53-11</b>
Remarks:SHACMAN M3000			Remarks:SHACMAN M3000 F3000		
KD0890			KD0891		
	Part No.	DZ96259240513		Part No.	189000240031
	CH part name	换挡杆支架总成		CH part name	换挡球头
	EN part name	Bracket		EN part name	Ball joint
	RU part name	кронштейн		RU part name	Настройка мяч головой
	Size:mm			Size:mm	145*120*50
	Weight:kg	1.25		Weight:kg	0.4
	NO.	<b>NO.53-2</b>		NO.	<b>NO.53-13</b>
Remarks:SHACMAN F3000			Remarks:SHACMAN F2000		
KD0892			KD0893		
	Part No.	199100240090		Part No.	199112240122
	CH part name	换挡调整球头		CH part name	换挡调整球头
	EN part name	Ball joint		EN part name	Ball joint
	RU part name	Настройка мяч головой		RU part name	Настройка мяч головой
	Size:mm			Size:mm	
	Weight:kg	0.168		Weight:kg	0.168
	NO.	<b>NO.53-10</b>		NO.	<b>NO.53-6</b>
Remarks:SHACMAN F2000			Remarks:SHACMAN F2000		

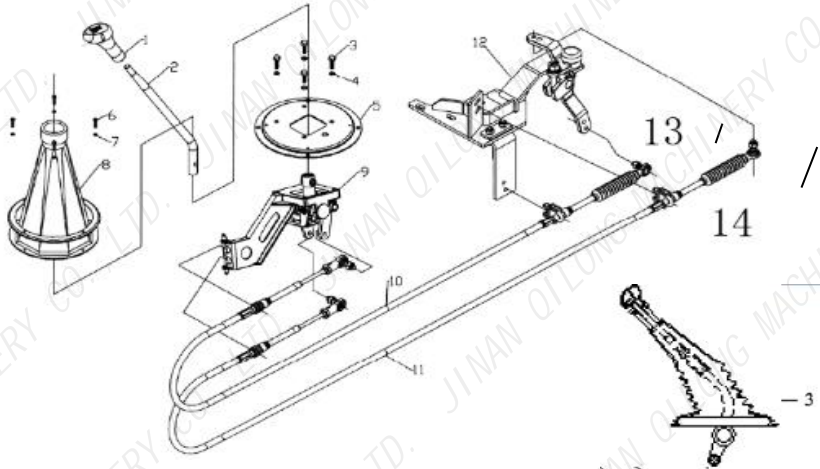

# SHACMAN(1)

	<p>Part No. DZ9112240701</p> <p>CH part name 换挡调节杆</p> <p>EN part name Bolt</p> <p>RU part name болт</p> <p>Size:mm 280*12*12</p> <p>Weight:kg 0.33</p> <p>NO. <b>NO.53-8</b></p>		<p>Part No. 1-99-951-042</p> <p>CH part name 换挡调节杆带球头</p> <p>EN part name Bolt</p> <p>RU part name болт</p> <p>Size:mm 310*12*12</p> <p>Weight:kg 0.5</p> <p>NO. <b>NO.53-8-6-10</b></p>
Remarks: SHACMAN F2000		Remarks: SHACMAN F2000	
	<p>Part No. DZ95259240333</p> <p>CH part name 新中间换力器</p> <p>EN part name Controller assy.</p> <p>RU part name Блок управления</p> <p>Size:mm</p> <p>Weight:kg 4.8</p> <p>NO. <b>NO.54-12</b></p>		<p>Part No. 81.96420.0324</p> <p>CH part name 变速杆防尘罩</p> <p>EN part name Dust cover</p> <p>RU part name пылезащитный чехол</p> <p>Size:mm 470*260*260</p> <p>Weight:kg 0.56</p> <p>NO. <b>NO.54-8</b></p>
Remarks:SHACMAN M3000		Remarks:SHACMAN F2000 F3000 M3000 X3000	
	<p>Part No. DZ91259240128</p> <p>CH part name 操纵器总成</p> <p>EN part name Controller assy.</p> <p>RU part name Блок управления</p> <p>Size:mm 280*180*150</p> <p>Weight:kg 3.8</p> <p>NO. <b>NO.54-9</b></p>		<p>Part No. DZ9114240564</p> <p>CH part name 变速杆防尘罩</p> <p>EN part name Dust cover</p> <p>RU part name пылезащитный чехол</p> <p>Size:mm 470*260*260</p> <p>Weight:kg 0.56</p> <p>NO. <b>NO.54-8</b></p>
Remarks:SHACMAN F3000		Remarks:SHACMAN F3000	
	<p>Part No. DZ9114240533</p> <p>CH part name 操纵器</p> <p>EN part name Controller assy.</p> <p>RU part name Блок управления</p> <p>Size:mm 280*180*150</p> <p>Weight:kg 3.5</p> <p>NO. <b>NO.54-9</b></p>		<p>Part No. DZ91259240163</p> <p>CH part name 操纵器总成</p> <p>EN part name Controller assy.</p> <p>RU part name Блок управления</p> <p>Size:mm 280*180*150</p> <p>Weight:kg 3.6</p> <p>NO. <b>NO.54-9</b></p>
Remarks:SHACMAN F3000		Remarks:SHACMAN F3000 新M3000	

# SHACMAN(1)

SHIFTING DEVECE		NO.54																													
	KD0902																														
			<table border="1"> <tr><td>Part No.</td><td>DZ9114240536</td></tr> <tr><td>CH part name</td><td>固定板</td></tr> <tr><td>EN part name</td><td>Fixed plate</td></tr> <tr><td>RU part name</td><td>крепления пластины</td></tr> <tr><td>Size:mm</td><td>260*260*0.2</td></tr> <tr><td>Weight:kg</td><td>0.65</td></tr> <tr><td>NO.</td><td><b>NO.54-5</b></td></tr> </table>	Part No.	DZ9114240536	CH part name	固定板	EN part name	Fixed plate	RU part name	крепления пластины	Size:mm	260*260*0.2	Weight:kg	0.65	NO.	<b>NO.54-5</b>														
	Part No.	DZ9114240536																													
	CH part name	固定板																													
	EN part name	Fixed plate																													
	RU part name	крепления пластины																													
	Size:mm	260*260*0.2																													
	Weight:kg	0.65																													
	NO.	<b>NO.54-5</b>																													
	Remarks:SHACMAN F3000																														
KD0903																															
		<table border="1"> <tr><td>Part No.</td><td>DZ91259240162</td></tr> <tr><td>CH part name</td><td>变速箱操纵杆</td></tr> <tr><td>EN part name</td><td>Shift rod assy.</td></tr> <tr><td>RU part name</td><td>Рычаг переключения скорости в сборе</td></tr> <tr><td>Size:mm</td><td></td></tr> <tr><td>Weight:kg</td><td>0.85</td></tr> <tr><td>NO.</td><td><b>NO.54-2</b></td></tr> </table>	Part No.	DZ91259240162	CH part name	变速箱操纵杆	EN part name	Shift rod assy.	RU part name	Рычаг переключения скорости в сборе	Size:mm		Weight:kg	0.85	NO.	<b>NO.54-2</b>															
Part No.	DZ91259240162																														
CH part name	变速箱操纵杆																														
EN part name	Shift rod assy.																														
RU part name	Рычаг переключения скорости в сборе																														
Size:mm																															
Weight:kg	0.85																														
NO.	<b>NO.54-2</b>																														
Remarks:SHACMAN F2000 DZ9114240557 DZ95259240017左置																															
KD0904		KD0905																													
	<table border="1"> <tr><td>Part No.</td><td>DZ93259240064</td></tr> <tr><td>CH part name</td><td>变速操纵杆(右置12档)</td></tr> <tr><td>EN part name</td><td>Shift rod assy.</td></tr> <tr><td>RU part name</td><td>Рычаг переключения скорости в сборе</td></tr> <tr><td>Size:mm</td><td></td></tr> <tr><td>Weight:kg</td><td>0.98</td></tr> <tr><td>NO.</td><td><b>NO.54-2</b></td></tr> </table>	Part No.	DZ93259240064	CH part name	变速操纵杆(右置12档)	EN part name	Shift rod assy.	RU part name	Рычаг переключения скорости в сборе	Size:mm		Weight:kg	0.98	NO.	<b>NO.54-2</b>		<table border="1"> <tr><td>Part No.</td><td>DZ93259240063</td></tr> <tr><td>CH part name</td><td>变速操纵杆(右置9档)</td></tr> <tr><td>EN part name</td><td>Shift rod assy.</td></tr> <tr><td>RU part name</td><td>Рычаг переключения скорости в сборе</td></tr> <tr><td>Size:mm</td><td></td></tr> <tr><td>Weight:kg</td><td>0.98</td></tr> <tr><td>NO.</td><td><b>NO.54-2</b></td></tr> </table>	Part No.	DZ93259240063	CH part name	变速操纵杆(右置9档)	EN part name	Shift rod assy.	RU part name	Рычаг переключения скорости в сборе	Size:mm		Weight:kg	0.98	NO.	<b>NO.54-2</b>
Part No.	DZ93259240064																														
CH part name	变速操纵杆(右置12档)																														
EN part name	Shift rod assy.																														
RU part name	Рычаг переключения скорости в сборе																														
Size:mm																															
Weight:kg	0.98																														
NO.	<b>NO.54-2</b>																														
Part No.	DZ93259240063																														
CH part name	变速操纵杆(右置9档)																														
EN part name	Shift rod assy.																														
RU part name	Рычаг переключения скорости в сборе																														
Size:mm																															
Weight:kg	0.98																														
NO.	<b>NO.54-2</b>																														
Remarks:SHACMAN F2000 F3000 新M3000 DZ93259240504/05左置		Remarks:SHACMAN F2000 F3000 新M3000																													
KD0906		KD0907																													
	<table border="1"> <tr><td>Part No.</td><td>DZ95259240007</td></tr> <tr><td>CH part name</td><td>换挡软轴总成</td></tr> <tr><td>EN part name</td><td>Shift tube</td></tr> <tr><td>RU part name</td><td>Трос переключения передач</td></tr> <tr><td>Size:mm</td><td>3200*50*50</td></tr> <tr><td>Weight:kg</td><td>2.56</td></tr> <tr><td>Price:usd</td><td><b>NO.54-10</b></td></tr> </table>	Part No.	DZ95259240007	CH part name	换挡软轴总成	EN part name	Shift tube	RU part name	Трос переключения передач	Size:mm	3200*50*50	Weight:kg	2.56	Price:usd	<b>NO.54-10</b>		<table border="1"> <tr><td>Part No.</td><td>DZ95259240008</td></tr> <tr><td>CH part name</td><td>换挡软轴总成</td></tr> <tr><td>EN part name</td><td>Shift tube</td></tr> <tr><td>RU part name</td><td>Трос переключения передач</td></tr> <tr><td>Size:mm</td><td>3200*50*50</td></tr> <tr><td>Weight:kg</td><td>2.56</td></tr> <tr><td>Price:usd</td><td><b>NO.54-11</b></td></tr> </table>	Part No.	DZ95259240008	CH part name	换挡软轴总成	EN part name	Shift tube	RU part name	Трос переключения передач	Size:mm	3200*50*50	Weight:kg	2.56	Price:usd	<b>NO.54-11</b>
Part No.	DZ95259240007																														
CH part name	换挡软轴总成																														
EN part name	Shift tube																														
RU part name	Трос переключения передач																														
Size:mm	3200*50*50																														
Weight:kg	2.56																														
Price:usd	<b>NO.54-10</b>																														
Part No.	DZ95259240008																														
CH part name	换挡软轴总成																														
EN part name	Shift tube																														
RU part name	Трос переключения передач																														
Size:mm	3200*50*50																														
Weight:kg	2.56																														
Price:usd	<b>NO.54-11</b>																														
Remarks:SHACMAN F2000 F3000		Remarks:SHACMAN F2000 F3000																													









# SHACMAN(1)

	<table border="1"> <tr><td>Part No.</td><td>DZ95259240141</td></tr> <tr><td>CH part name</td><td>换挡软轴总成</td></tr> <tr><td>EN part name</td><td>Shift tube</td></tr> <tr><td>RU part name</td><td>Трос переключения передач</td></tr> <tr><td>Size:mm</td><td>4100*50*50</td></tr> <tr><td>Weight:kg</td><td>1.8</td></tr> <tr><td>NO.</td><td><b>NO.54-10</b></td></tr> </table>	Part No.	DZ95259240141	CH part name	换挡软轴总成	EN part name	Shift tube	RU part name	Трос переключения передач	Size:mm	4100*50*50	Weight:kg	1.8	NO.	<b>NO.54-10</b>		<table border="1"> <tr><td>Part No.</td><td>DZ95259240142</td></tr> <tr><td>CH part name</td><td>换挡软轴总成</td></tr> <tr><td>EN part name</td><td>Shift tube</td></tr> <tr><td>RU part name</td><td>Трос переключения передач</td></tr> <tr><td>Size:mm</td><td>4100*50*50</td></tr> <tr><td>Weight:kg</td><td>1.8</td></tr> <tr><td>NO.</td><td><b>NO.54-11</b></td></tr> </table>	Part No.	DZ95259240142	CH part name	换挡软轴总成	EN part name	Shift tube	RU part name	Трос переключения передач	Size:mm	4100*50*50	Weight:kg	1.8	NO.	<b>NO.54-11</b>
Part No.	DZ95259240141																														
CH part name	换挡软轴总成																														
EN part name	Shift tube																														
RU part name	Трос переключения передач																														
Size:mm	4100*50*50																														
Weight:kg	1.8																														
NO.	<b>NO.54-10</b>																														
Part No.	DZ95259240142																														
CH part name	换挡软轴总成																														
EN part name	Shift tube																														
RU part name	Трос переключения передач																														
Size:mm	4100*50*50																														
Weight:kg	1.8																														
NO.	<b>NO.54-11</b>																														
Remarks: SHACMAN F3000 新M3000		Remarks: SHACMAN F3000 新M3000																													
	<table border="1"> <tr><td>Part No.</td><td>DZ93259240058</td></tr> <tr><td>CH part name</td><td>换挡软轴总成</td></tr> <tr><td>EN part name</td><td>Shift tube</td></tr> <tr><td>RU part name</td><td>Трос переключения передач</td></tr> <tr><td>Size:mm</td><td>3900*50*50</td></tr> <tr><td>Weight:kg</td><td>2.7</td></tr> <tr><td>NO.</td><td><b>NO.54-10</b></td></tr> </table>	Part No.	DZ93259240058	CH part name	换挡软轴总成	EN part name	Shift tube	RU part name	Трос переключения передач	Size:mm	3900*50*50	Weight:kg	2.7	NO.	<b>NO.54-10</b>		<table border="1"> <tr><td>Part No.</td><td>DZ93259240056</td></tr> <tr><td>CH part name</td><td>换挡软轴总成</td></tr> <tr><td>EN part name</td><td>Shift tube</td></tr> <tr><td>RU part name</td><td>Трос переключения передач</td></tr> <tr><td>Size:mm</td><td>3900*50*50</td></tr> <tr><td>Weight:kg</td><td>2.7</td></tr> <tr><td>NO.</td><td><b>NO.54-11</b></td></tr> </table>	Part No.	DZ93259240056	CH part name	换挡软轴总成	EN part name	Shift tube	RU part name	Трос переключения передач	Size:mm	3900*50*50	Weight:kg	2.7	NO.	<b>NO.54-11</b>
Part No.	DZ93259240058																														
CH part name	换挡软轴总成																														
EN part name	Shift tube																														
RU part name	Трос переключения передач																														
Size:mm	3900*50*50																														
Weight:kg	2.7																														
NO.	<b>NO.54-10</b>																														
Part No.	DZ93259240056																														
CH part name	换挡软轴总成																														
EN part name	Shift tube																														
RU part name	Трос переключения передач																														
Size:mm	3900*50*50																														
Weight:kg	2.7																														
NO.	<b>NO.54-11</b>																														
Remarks: SHACMAN F3000		Remarks: SHACMAN F3000																													
	<table border="1"> <tr><td>Part No.</td><td>DZ95259240009</td></tr> <tr><td>CH part name</td><td>软轴支架及转换机构</td></tr> <tr><td>EN part name</td><td>Conversion mechanism</td></tr> <tr><td>RU part name</td><td>механизм преобразования</td></tr> <tr><td>Size:mm</td><td></td></tr> <tr><td>Weight:kg</td><td>1.15</td></tr> <tr><td>NO.</td><td><b>NO.54-12</b></td></tr> </table>	Part No.	DZ95259240009	CH part name	软轴支架及转换机构	EN part name	Conversion mechanism	RU part name	механизм преобразования	Size:mm		Weight:kg	1.15	NO.	<b>NO.54-12</b>		<table border="1"> <tr><td>Part No.</td><td>DZ95259240138</td></tr> <tr><td>CH part name</td><td>换挡转换机构总成</td></tr> <tr><td>EN part name</td><td>Conversion mechanism</td></tr> <tr><td>RU part name</td><td>механизм преобразования</td></tr> <tr><td>Size:mm</td><td></td></tr> <tr><td>Weight:kg</td><td>0.85</td></tr> <tr><td>NO.</td><td><b>NO.54-12</b></td></tr> </table>	Part No.	DZ95259240138	CH part name	换挡转换机构总成	EN part name	Conversion mechanism	RU part name	механизм преобразования	Size:mm		Weight:kg	0.85	NO.	<b>NO.54-12</b>
Part No.	DZ95259240009																														
CH part name	软轴支架及转换机构																														
EN part name	Conversion mechanism																														
RU part name	механизм преобразования																														
Size:mm																															
Weight:kg	1.15																														
NO.	<b>NO.54-12</b>																														
Part No.	DZ95259240138																														
CH part name	换挡转换机构总成																														
EN part name	Conversion mechanism																														
RU part name	механизм преобразования																														
Size:mm																															
Weight:kg	0.85																														
NO.	<b>NO.54-12</b>																														
Remarks: SHACMAN F3000 DZ95259240002		Remarks: SHACMAN F3000 新M3000																													
	<table border="1"> <tr><td>Part No.</td><td>DZ91259240131/0139</td></tr> <tr><td>CH part name</td><td>摇臂调节杆总成</td></tr> <tr><td>EN part name</td><td>Rocker arm adjustment lever assembly</td></tr> <tr><td>RU part name</td><td>рокер регулирующий стержень</td></tr> <tr><td>Size:mm</td><td></td></tr> <tr><td>Weight:kg</td><td>0.53</td></tr> <tr><td>NO.</td><td><b>NO.54-12</b></td></tr> </table>	Part No.	DZ91259240131/0139	CH part name	摇臂调节杆总成	EN part name	Rocker arm adjustment lever assembly	RU part name	рокер регулирующий стержень	Size:mm		Weight:kg	0.53	NO.	<b>NO.54-12</b>		<table border="1"> <tr><td>Part No.</td><td>DZ95259240139</td></tr> <tr><td>CH part name</td><td>操纵器支架摇臂</td></tr> <tr><td>EN part name</td><td>rocker arm</td></tr> <tr><td>RU part name</td><td>рокер</td></tr> <tr><td>Size:mm</td><td></td></tr> <tr><td>Weight:kg</td><td>0.33</td></tr> <tr><td>NO.</td><td><b>NO.54-12</b></td></tr> </table>	Part No.	DZ95259240139	CH part name	操纵器支架摇臂	EN part name	rocker arm	RU part name	рокер	Size:mm		Weight:kg	0.33	NO.	<b>NO.54-12</b>
Part No.	DZ91259240131/0139																														
CH part name	摇臂调节杆总成																														
EN part name	Rocker arm adjustment lever assembly																														
RU part name	рокер регулирующий стержень																														
Size:mm																															
Weight:kg	0.53																														
NO.	<b>NO.54-12</b>																														
Part No.	DZ95259240139																														
CH part name	操纵器支架摇臂																														
EN part name	rocker arm																														
RU part name	рокер																														
Size:mm																															
Weight:kg	0.33																														
NO.	<b>NO.54-12</b>																														
Remarks: SHACMAN F3000 新M3000		Remarks: SHACMAN F3000 新M3000																													





# SHACMAN(1)

	<table border="1"> <tr><td>Part No.</td><td>HDGXLB-01-02</td></tr> <tr><td>CH part name</td><td>换挡杆下球头修理包</td></tr> <tr><td>EN part name</td><td>Shift repair kit</td></tr> <tr><td>RU part name</td><td>переход аптечка</td></tr> <tr><td>Size:mm</td><td></td></tr> <tr><td>Weight:kg</td><td>0.32</td></tr> <tr><td>NO.</td><td><b>NO.54-3</b></td></tr> </table>	Part No.	HDGXLB-01-02	CH part name	换挡杆下球头修理包	EN part name	Shift repair kit	RU part name	переход аптечка	Size:mm		Weight:kg	0.32	NO.	<b>NO.54-3</b>		<table border="1"> <tr><td>Part No.</td><td>DZ93259240058/0056QT</td></tr> <tr><td>CH part name</td><td>换挡选档线球头</td></tr> <tr><td>EN part name</td><td>Conversion mechanism</td></tr> <tr><td>RU part name</td><td>механизм преобразования</td></tr> <tr><td>Size:mm</td><td></td></tr> <tr><td>Weight:kg</td><td>0.1</td></tr> <tr><td>NO.</td><td><b>NO.54-13-14</b></td></tr> </table>	Part No.	DZ93259240058/0056QT	CH part name	换挡选档线球头	EN part name	Conversion mechanism	RU part name	механизм преобразования	Size:mm		Weight:kg	0.1	NO.	<b>NO.54-13-14</b>
Part No.	HDGXLB-01-02																														
CH part name	换挡杆下球头修理包																														
EN part name	Shift repair kit																														
RU part name	переход аптечка																														
Size:mm																															
Weight:kg	0.32																														
NO.	<b>NO.54-3</b>																														
Part No.	DZ93259240058/0056QT																														
CH part name	换挡选档线球头																														
EN part name	Conversion mechanism																														
RU part name	механизм преобразования																														
Size:mm																															
Weight:kg	0.1																														
NO.	<b>NO.54-13-14</b>																														
Remarks: SHACMAN F2000 F3000 M3000 X3000		Remarks: SHACMAN F2000 F3000 M3000 X3000																													
	<table border="1"> <tr><td>Part No.</td><td>DZ93259240069</td></tr> <tr><td>CH part name</td><td>换挡手柄10档</td></tr> <tr><td>EN part name</td><td>Shift lever</td></tr> <tr><td>RU part name</td><td>ручка переключения передач</td></tr> <tr><td>Size:mm</td><td>150*60*50</td></tr> <tr><td>Weight:kg</td><td>0.16</td></tr> <tr><td>NO.</td><td><b>NO.54-1</b></td></tr> </table>	Part No.	DZ93259240069	CH part name	换挡手柄10档	EN part name	Shift lever	RU part name	ручка переключения передач	Size:mm	150*60*50	Weight:kg	0.16	NO.	<b>NO.54-1</b>		<table border="1"> <tr><td>Part No.</td><td>81.32616.0007</td></tr> <tr><td>CH part name</td><td>换挡杆间隔元件</td></tr> <tr><td>EN part name</td><td>Shift lever seat</td></tr> <tr><td>RU part name</td><td>рычаг переключения передач сиденья</td></tr> <tr><td>Size:mm</td><td>260*260*65</td></tr> <tr><td>Weight:kg</td><td>0.28</td></tr> <tr><td>NO.</td><td><b>NO.54-3</b></td></tr> </table>	Part No.	81.32616.0007	CH part name	换挡杆间隔元件	EN part name	Shift lever seat	RU part name	рычаг переключения передач сиденья	Size:mm	260*260*65	Weight:kg	0.28	NO.	<b>NO.54-3</b>
Part No.	DZ93259240069																														
CH part name	换挡手柄10档																														
EN part name	Shift lever																														
RU part name	ручка переключения передач																														
Size:mm	150*60*50																														
Weight:kg	0.16																														
NO.	<b>NO.54-1</b>																														
Part No.	81.32616.0007																														
CH part name	换挡杆间隔元件																														
EN part name	Shift lever seat																														
RU part name	рычаг переключения передач сиденья																														
Size:mm	260*260*65																														
Weight:kg	0.28																														
NO.	<b>NO.54-3</b>																														
Remarks: SHACMAN F2000 F3000		Remarks: SHACMAN F2000 F3000 M3000 X3000																													
	<table border="1"> <tr><td>Part No.</td><td>DZ9114240556</td></tr> <tr><td>CH part name</td><td>换挡手柄9档</td></tr> <tr><td>EN part name</td><td>Shift lever</td></tr> <tr><td>RU part name</td><td>ручка переключения передач</td></tr> <tr><td>Size:mm</td><td>150*60*50</td></tr> <tr><td>Weight:kg</td><td>0.16</td></tr> <tr><td>NO.</td><td><b>NO.54-1</b></td></tr> </table>	Part No.	DZ9114240556	CH part name	换挡手柄9档	EN part name	Shift lever	RU part name	ручка переключения передач	Size:mm	150*60*50	Weight:kg	0.16	NO.	<b>NO.54-1</b>		<table border="1"> <tr><td>Part No.</td><td>12JS160T-1708010-17</td></tr> <tr><td>CH part name</td><td>预选阀 12档</td></tr> <tr><td>EN part name</td><td>Shift lever</td></tr> <tr><td>RU part name</td><td>ручка переключения передач</td></tr> <tr><td>Size:mm</td><td>150*60*50</td></tr> <tr><td>Weight:kg</td><td>0.16</td></tr> <tr><td>NO.</td><td><b>NO.54-1</b></td></tr> </table>	Part No.	12JS160T-1708010-17	CH part name	预选阀 12档	EN part name	Shift lever	RU part name	ручка переключения передач	Size:mm	150*60*50	Weight:kg	0.16	NO.	<b>NO.54-1</b>
Part No.	DZ9114240556																														
CH part name	换挡手柄9档																														
EN part name	Shift lever																														
RU part name	ручка переключения передач																														
Size:mm	150*60*50																														
Weight:kg	0.16																														
NO.	<b>NO.54-1</b>																														
Part No.	12JS160T-1708010-17																														
CH part name	预选阀 12档																														
EN part name	Shift lever																														
RU part name	ручка переключения передач																														
Size:mm	150*60*50																														
Weight:kg	0.16																														
NO.	<b>NO.54-1</b>																														
Remarks: SHACMAN F2000 F3000 新M3000		Remarks: SHACMAN F3000																													
	<table border="1"> <tr><td>Part No.</td><td>DZ93259594101</td></tr> <tr><td>CH part name</td><td>支架总成(R)</td></tr> <tr><td>EN part name</td><td>Right bracket</td></tr> <tr><td>RU part name</td><td>правая скобки</td></tr> <tr><td>Size:mm</td><td></td></tr> <tr><td>Weight:kg</td><td>1.45</td></tr> <tr><td>NO.</td><td><b>NO.55-11</b></td></tr> </table>	Part No.	DZ93259594101	CH part name	支架总成(R)	EN part name	Right bracket	RU part name	правая скобки	Size:mm		Weight:kg	1.45	NO.	<b>NO.55-11</b>		<table border="1"> <tr><td>Part No.</td><td>DZ93259594100</td></tr> <tr><td>CH part name</td><td>支架总成(L)</td></tr> <tr><td>EN part name</td><td>Left bracket</td></tr> <tr><td>RU part name</td><td>слева от</td></tr> <tr><td>Size:mm</td><td></td></tr> <tr><td>Weight:kg</td><td>1.45</td></tr> <tr><td>NO.</td><td><b>NO.55-2</b></td></tr> </table>	Part No.	DZ93259594100	CH part name	支架总成(L)	EN part name	Left bracket	RU part name	слева от	Size:mm		Weight:kg	1.45	NO.	<b>NO.55-2</b>
Part No.	DZ93259594101																														
CH part name	支架总成(R)																														
EN part name	Right bracket																														
RU part name	правая скобки																														
Size:mm																															
Weight:kg	1.45																														
NO.	<b>NO.55-11</b>																														
Part No.	DZ93259594100																														
CH part name	支架总成(L)																														
EN part name	Left bracket																														
RU part name	слева от																														
Size:mm																															
Weight:kg	1.45																														
NO.	<b>NO.55-2</b>																														
Remarks: SHACMAN F3000 DZ9118593008		Remarks: SHACMAN F3000 DZ9118593007																													



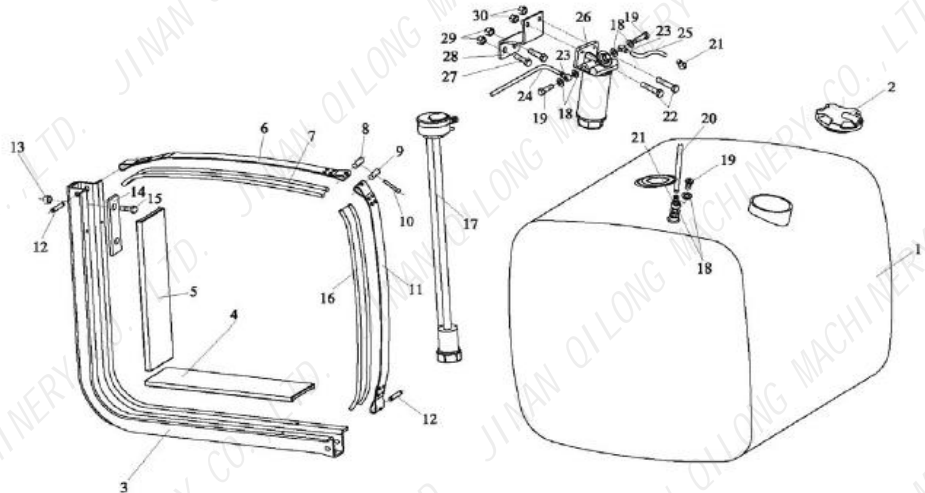
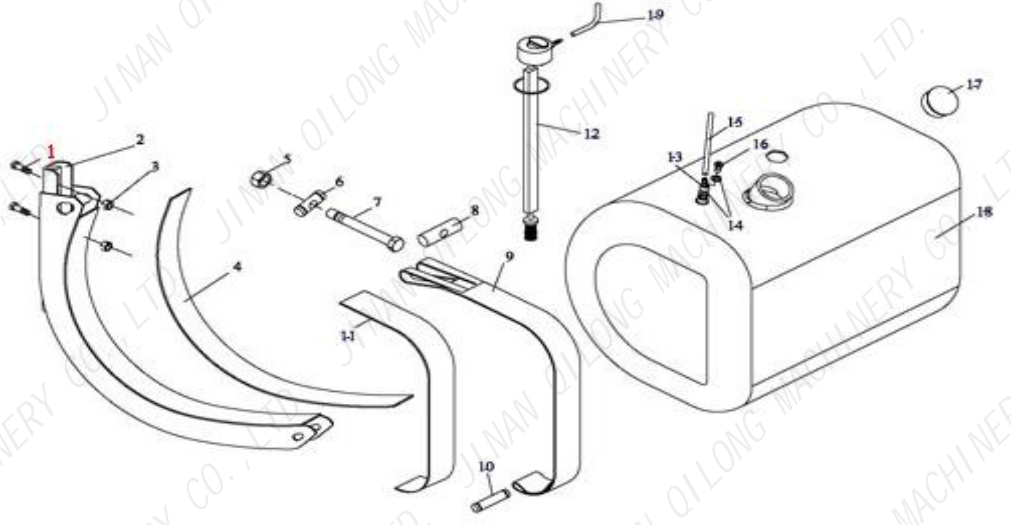



# SHACMAN(1)

KD0924			KD0925		
	Part No.	DZ9112590884		Part No.	DZ9112590883
	CH part name	右支架总成R		CH part name	支架总成(L)
	EN part name	Right bracket		EN part name	Left bracket
	RU part name	правая скобки		RU part name	слева от
	Size:mm			Size:mm	
	Weight:kg	1.54		Weight:kg	1.54
	NO.	<b>NO.55-11</b>		NO.	<b>NO.55-2</b>
Remarks:SHACMAN F3000			Remarks:SHACMAN F3000		
KD0926			KD0927		
	Part No.	DZ95259593003		Part No.	DZ95259593002
	CH part name	右支架总成(R)		CH part name	支架总成(L)
	EN part name	Right bracket		EN part name	Left bracket
	RU part name	правая скобки		RU part name	слева от
	Size:mm			Size:mm	
	Weight:kg	0.72		Weight:kg	1.85
	NO.	<b>NO.55-11</b>		NO.	<b>NO.55-2</b>
Remarks:SHACMAN F3000			Remarks:SHACMAN F3000		
KD0928			KD0929		
	Part No.	DZ9114598696		Part No.	DZ9114598695
	CH part name	右托架(R)		CH part name	支架总成(L)
	EN part name	Right bracket		EN part name	Left bracket
	RU part name	правая скобки		RU part name	слева от
	Size:mm			Size:mm	
	Weight:kg	2.3		Weight:kg	2.3
	NO.	<b>NO.55-11</b>		NO.	<b>NO.55-2</b>
Remarks:SHACMAN F2000			Remarks:SHACMAN F2000		
KD0930			KD0931		
	Part No.	DZ95259591010		Part No.	DZ9112590889
	CH part name	变速器悬置横梁		CH part name	横梁总成
	EN part name	Cross member assy		EN part name	Cross member assy
	RU part name	кросс - астрид		RU part name	кросс - астрид
	Size:mm			Size:mm	
	Weight:kg	3.5		Weight:kg	4.8
	NO.	<b>NO.55-10</b>		NO.	<b>NO.55-10</b>
Remarks:SHACMAN F3000			Remarks:SHACMAN F3000 DZ95259590060		

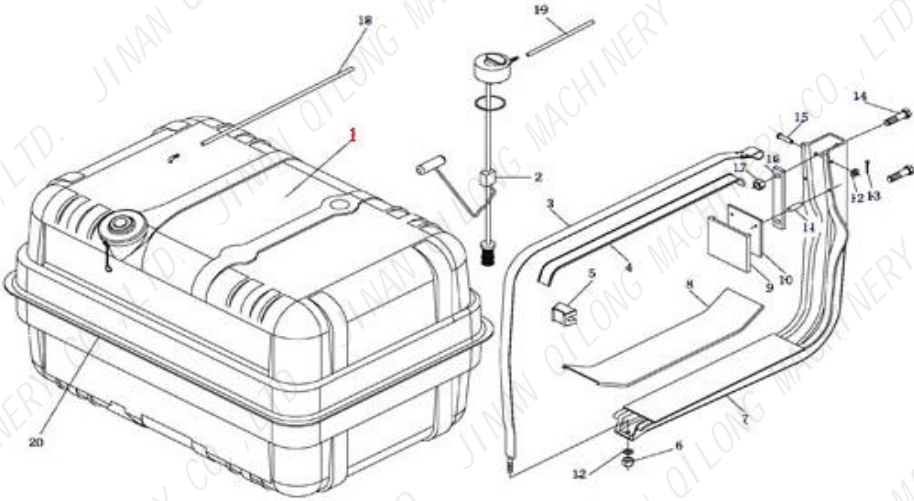
# SHACMAN(1)

ALUMINUM ALLOY FUEL TANK/ASSEMBLY		NO.48	ALUMINUM ALLOY FUEL TANK/ASSEMBLY		NO.C48		
							
KD0842		KD0843					
	Part No.	DZ91319554310			Part No.	DZ9114551544	
	CH part name	油箱支架			CH part name	油箱支架	
	EN part name	Bracket			EN part name	Bracket	
	RU part name	кронштейн			RU part name	кронштейн	
	Size:mm				Size:mm		
	Weight:kg				Weight:kg		
NO.	<b>NO.48-3</b>		NO.	<b>NO.48-3</b>			
Remarks:SHACMAN F3000			Remarks:SHACMAN F3000				
KD0844		KD0845					
	Part No.	DZ9114550139			Part No.	DZ9114552740	
	CH part name	400L油箱 D型			CH part name	400L铝合金油箱	
	EN part name	Fuel tank			EN part name	Fuel tank	
	RU part name	Топливный бак в сборе400L			RU part name	Топливный бак в сборе400L	
	Size:mm	820*700*680			Size:mm	820*700*680	
	Weight:kg	20			Weight:kg	25	
NO.	<b>NO.C48-18</b>		NO.	<b>NO.48-1</b>			
Remarks:SHACMAN F2000 F3000 DZ9114550711			Remarks:SHACMAN F2000 F3000 350L/400L/500L/600L				

# SHACMAN(1)

ALUMINUM ALLOY FUEL TANK/ASSEMBLY		NO.D48	
	KD0846		
		Part No.	DZ9114552701
	CH part name	护垫	
	EN part name	Protector	
	RU part name	защитник	
	Size:mm		
	Weight:kg	0.25	
	NO.	<b>NO.48-7</b>	
Remarks:SHACMAN F2000 F3000 199114550012			
	KD0847		
		Part No.	DZ9114552760
	CH part name	油箱支架	
	EN part name	Bracket	
	RU part name	кронштейн	
	Size:mm	730*670*120	
	Weight:kg	6.2	
	NO.	<b>NO.D48-7</b>	
Remarks:SHACMAN F2000 F3000			
KD0848		KD0849	
	Part No.	199112270013	
	CH part name	紧固带	
	EN part name	Fastening strap assembly	
	RU part name	fasteming лямки ассамблеи	
	Size:mm		
	Weight:kg	0.16	
	NO.	<b>NO.D48-3</b>	
Remarks:SHACMAN F2000 F3000			
		Part No.	DZ9114550046
	CH part name	380L油箱	
	EN part name	Fuel tank	
	RU part name	Бак топливный380L	
	Size:mm	800*750*650	
	Weight:kg	32	
	NO.	<b>NO.D48-1</b>	
Remarks:SHACMAN F2000 F3000			
KD0850		KD0851	
	Part No.	DZ9114160034	
	CH part name	430拉式压盘总成	
	EN part name	430 Platen assy.	
	RU part name	Корзина сцепления 430 в сборе	
	Size:mm	500*500*130	
	Weight:kg	36.4	
	NO.	<b>NO.49-2</b>	
Remarks: SHACMAN F2000 F3000 DZ9114160031 DZ9114160017			
		Part No.	DZ1560160012
	CH part name	拉式从动盘	
	EN part name	430 Clutch disc	
	RU part name	Диск сцепления	
	Size:mm	430*430*65	
	Weight:kg	8.45	
	NO.	<b>NO.49-1</b>	
Remarks: SHACMAN F2000 F3000			